



Product Information

Gateway

For Connecting EnDat
Encoders to PROFINET IO

PROFINET gateway

For connecting EnDat encoders

Encoders with EnDat interface for connection via gateway

Absolute encoders from HEIDENHAIN with **EnDat interface** are suitable for PROFINET IO. The encoder is electrically connected through a **gateway**. The complete interface electronics are integrated in the gateway, as well as a voltage converter for supplying EnDat encoders with DC 5V $\pm 5\%$. This offers a number of benefits:

- Simple connection of the field bus cables.
- Encoder dimensions remain small.
- No temperature restrictions for the encoder. All temperature-sensitive components are in the gateway.
- No bus interruption when an encoder is exchanged.

Besides the EnDat encoder connector, the gateway provides connections for PROFINET and the power supply.

Since the gateway is a bus member, the cable to the encoder is not a stub line, although it can be up to 40 meters long.

PROFINET IO

PROFINET IO is the open Industrial Ethernet Standard for industrial communication. It builds on the field-proven function model of PROFIBUS-DP, but uses fast Ethernet technology as physical transmission medium and is therefore tailored for fast transmission of I/O data. It offers the possibility of transmission for required data, parameters and IT functions at the same time.

Physical characteristics

HEIDENHAIN encoders and the gateway are connected to PROFINET in accordance with 100BASE-TX (IEEE 802.3 Clause 25) via one shielded twisted pair of wires per direction. The data transfer rate is 100 Mbit/s (Fast Ethernet).

PROFINET profile

HEIDENHAIN encoders and gateways fulfill the definitions as per Profile 3.162, Version 4.1. The device profile describes the encoder functions. Rotary encoders support the functions of class 4 (full range of scaling and preset functions). The functions supported by the gateway vary depending on the connected encoder. More information about PROFINET can be obtained from the PROFIBUS user organization (PNO).

Commissioning

To put an encoder with PROFINET interface into service, a general station description (GSD or GSDML) file must be downloaded and imported into the configuration software. The GSD or GSDML contains the execution parameters required for a PROFINET IO device.

Encoders or gateway with PROFINET

Encoders with integrated PROFINET interface or the gateway are directly integrated in the network. Addresses are distributed automatically over a protocol integrated in PROFINET. A PROFINET-IO field device is addressed within a network through its physical device MAC address. The encoders feature two double-color LEDs for diagnostics of the bus and the device.

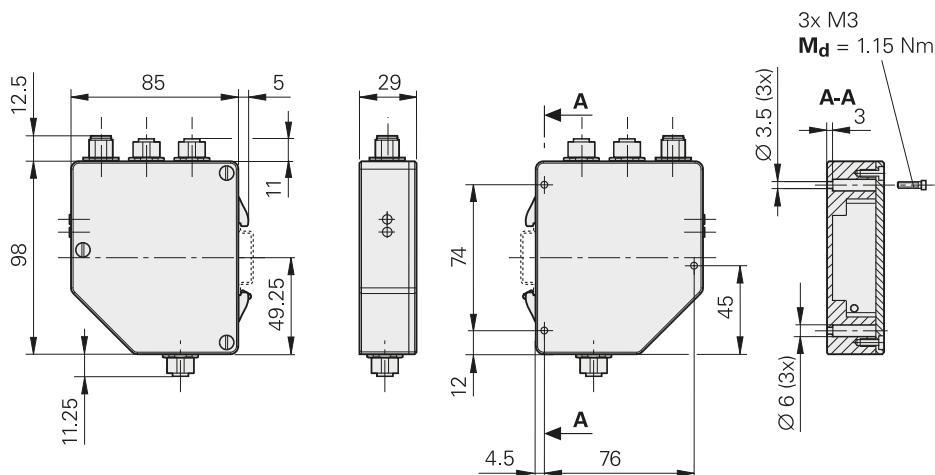

mm

Tolerancing ISO 8015
ISO 2768 - m H
< 6 mm: $\pm 0.2 \text{ mm}$

Specifications	Gateway PROFINET IO
Input	For absolute linear, angle and rotary encoders with ordering designation EnDat22 (multiturn rotary encoders with battery buffer are not supported)
Connection	M12 flange socket (female) 8-pin
Cable length	≤ 40 m (with HEIDENHAIN cable), greater lengths upon request
Power supply of encoder	DC 5 V ±5 % (max. 400 mA)
Output	PROFINET IO Functions as per Profile 3.162, Version 4.1 (see separate table)
Operating status displays	Integrated LED displays: <ul style="list-style-type: none"> • "Module" ≙ Status of gateway • "Bus" ≙ PROFINET status
Bus connection (PORT 1, PORT 2, U _P)	3 x M12 connecting element, 4-pin
Power supply	DC 9 V to 36 V
Power consumption	Maximum: 9 V: ≤ 5.3 W; 36 V: ≤ 5.3 W (including residual ripple) Typical: 2.4 W + P _{encoder} × 1.33
Operating temperature	-40 °C ... +80 °C
Vibration 50 Hz to 2000 Hz Shock 11 ms	≤ 100 m/s ² (EN 60068-2-6) ≤ 300 m/s ² (EN 60068-2-27)
Protection EN 60529	IP65
Mass	≈ 400 g
Dimensions	≈ 150 mm x 90 mm x 30 mm
Fastening	Top-hat rail mounting

Supported functions

Supported functions	Class	Rotary encoders		Linear encoders
		Singletum	Multitum	
Position value	3, 4	✓	✓	✓
Isochronous mode	3, 4	✓	✓	✓
Functionality of class 4	4	✓	✓	✓
Scaling function	4	✓	✓	–
Measuring units per revolution	4	✓	✓	–
Total measuring range	4	✓	✓	–
Cyclic operation (binary scaling)	4	✓	✓	–
Noncyclic operation	4	✓	✓	–
Preset	4	✓	✓	✓
Code sequence	4	✓	✓	✓
Preset control G1_XIST1	4	✓	✓	✓
Compatibility mode (encoder profile V.3.1)	3, 4	✓	✓	✓
Operating time	3, 4	✓	✓	✓
Speed	3, 4	✓	✓	✓
Profile version	3, 4	✓	✓	✓
Permanent storage of the offset value	4	✓	✓	✓
Identification & maintenance (I & M)		✓	✓	✓
External firmware upgrade		✓	✓	✓

Electrical connection

PROFINET

Connection

PROFINET and the power supply are connected via the M12 connecting elements. The necessary mating connectors are:

Ports 1 and 2

M12 coupling (male) 4-pin, D-coded

Power supply

M12 connector, 4-pin, A-coded



Pin layout

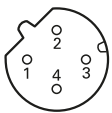

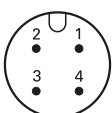

Ports 1 and 2 4-pin connector (female) M12 D-coded 					
	Position values				
	1	2	3	4	Housing
PORT 1/2	Tx+	Rx+	Tx-	Rx-	Shield

Power supply 4-pin coupling (male) M12 A-coded 				
	1	3	2	4
	Up	0V	Secondary Up	0V

Power should be supplied via the Up pin. The secondary Up pin can be used for secondary power supply (normally not to be assigned, not suitable for looping through of Up).

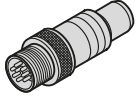
Comprehensive descriptions of all available interfaces as well as general electrical information is included in the *Interfaces of HEIDENHAIN Encoders* catalog, ID 1078628-xx.

Encoders with EnDat interface

Mating connector: 8-pin coupling, M12   								
	Power supply				Absolute position values			
	8	2	5	1	3	4	7	6
	U_P	Sensor U_P	0V	Sensor 0V	DATA	DATA	CLOCK	CLOCK
	Brown/Green	Blue	White/Green	White	Gray	Pink	Violet	Yellow

Cable shield connected to housing; **U_P** = power supply voltage

Sensor: The sensor line is connected in the encoder with the corresponding power line.

Vacant pins or wires must not be used.

HEIDENHAIN

DR. JOHANNES HEIDENHAIN GmbH

Dr.-Johannes-Heidenhain-Straße 5

83301 Traunreut, Germany

☎ +49 8669 31-0

☎ +49 8669 32-5061

E-mail: info@heidenhain.de

www.heidenhain.de

This Product Information supersedes all previous editions, which thereby become invalid. The basis for ordering from HEIDENHAIN is always the Product Information document edition valid when the order is made.

For more information: Adhere to the information in the following documents to ensure the correct and intended operation of the encoder:

- | | |
|---|-----------|
| • <i>Rotary Encoders</i> catalog | 349529-xx |
| • <i>Position Encoders for Servo Drives</i> catalog | 208922-xx |
| • <i>Angle Encoders with Integral Bearing</i> catalog | 951109-xx |
| • <i>Linear Encoders for Numerically Controlled Machine Tools</i> catalog | 571470-xx |