



HEIDENHAIN



TNC 640

Contouring Control for
Machining Centers and
Milling-Turning Machines



03/2020



**TNC 640
with 24-inch
touchscreen**



**TNC 640
with 19-inch
touchscreen**



**TNC 640
with 19-inch
touchscreen (portrait)**



The functions and specifications described in this brochure apply to the TNC 640 with NC SW 34059x-10

Contents

The TNC 640 . . .

Where can it be used?	Versatile The TNC contouring control for milling and milling-turning machines	4
What does it look like?	Intuitive and user-friendly State-of-the-art multitouch operation Highly practical user interface	6
What can it do?	Complete part machining Milling, turning, and grinding on one machine (option)	10
	Fast and reliable machining at high contour fidelity Dynamic Precision Optimal tool guidance by the TNC 640 Machining and measuring 3-D contours	12
	Machining with five axes Guided tool tip TNC 640-controlled swivel head and rotary table	17
	Intelligent machining Dynamic Collision Monitoring option (DCM) Dynamic Efficiency Active Chatter Control option (ACC) Adaptive Feed Control option (AFC) Machine any contour slot with trochoidal milling Optimized roughing processes with OCM (option) Global Program Settings (option)	20
	Automated machining The TNC 640 measures, manages, and communicates Pallet management and serial machining Tool management and workspace monitoring	28
	Minimize setup times The TNC 640 makes setup easy	31
	How is it programmed?	Programming, editing, and testing A full range of possibilities with the TNC 640 Graphical support in any scenario
Programming in the shop Straightforward function keys for complex contours Programing free contours and Data Matrix codes Practical cycles for recurring operations Practical turning cycles (option) Practical functions for grinding and dressing (option) Reusing programmed contour elements Rapid availability of all information		35
Open to outside information Processing CAD files with the TNC 640 Uniformly digital job management with Connected Machining StateMonitor: collect and evaluate machine data The TNC 640 programming station		44
What accessories are there?	Workpiece measurement Setup, preset setting, and measuring with touch trigger probes	50
	Tool measurement Measuring length, radius, and wear inside the machine	51
	Inspecting and optimizing machine accuracy Easy calibration of rotary axes with KinematicsOpt (option)	52
	Positioning with an electronic handwheel Fine motion control of axes	53
... At a glance	Overview User functions, accessories, options, specifications, comparison of controls	54

Versatile

The TNC 640 contouring control for milling and milling-turning machines

For more than 40 years, TNC controls from HEIDENHAIN have proven themselves every day on milling machines, machining centers, and drilling machines. Over this period, they have been continually further developed, with focus placed on an operating approach tailored to the needs of the machine operator.

Multitouch operation

The TNC 640 comes with either a keyboard and conventional screen or a keyboard and touchscreen that puts zooming, rotating, and dragging all at your fingertips for fast and easy operation of the TNC 640.

Shop-oriented programming

The TNC 640 lets you program conventional milling, drilling, turning, and grinding operations right on the machine using the shop-oriented Klartext conversational programming language from HEIDENHAIN. With helpful dialog guidance and informative visual aids, the TNC 640 provides optimal programming support, including for turning operations.

For standard machining operations and even complex applications, a wealth of practical machining and coordinate transformation cycles are at your beck and call.

Offline programming

The TNC 640 is easy to program remotely as well. Its Ethernet interface ensures extremely short upload times, even for long programs.

Easy to operate

When it comes to simple machining tasks, such as face milling or face turning, you don't need to write a program on the TNC 640. That's because the TNC 640 makes manual control equally easy—either by means of the axis keys or, for maximum sensitivity, with an electronic handwheel.

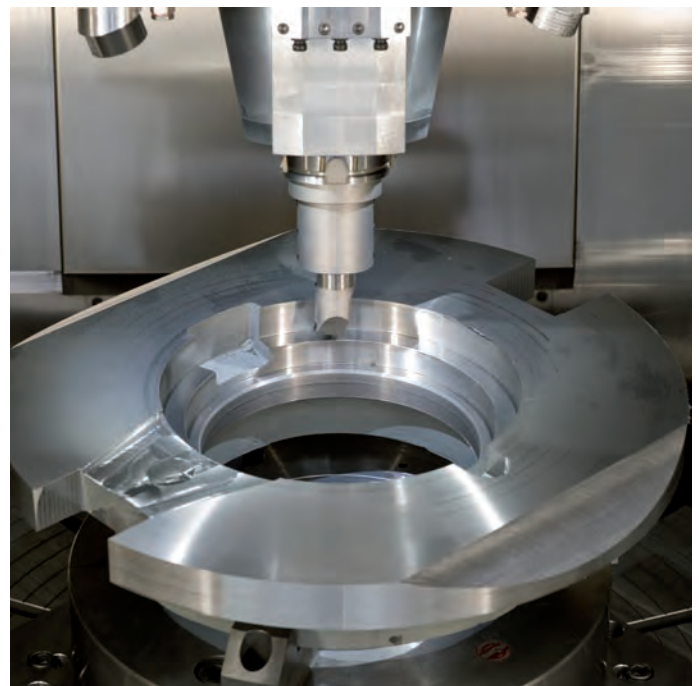
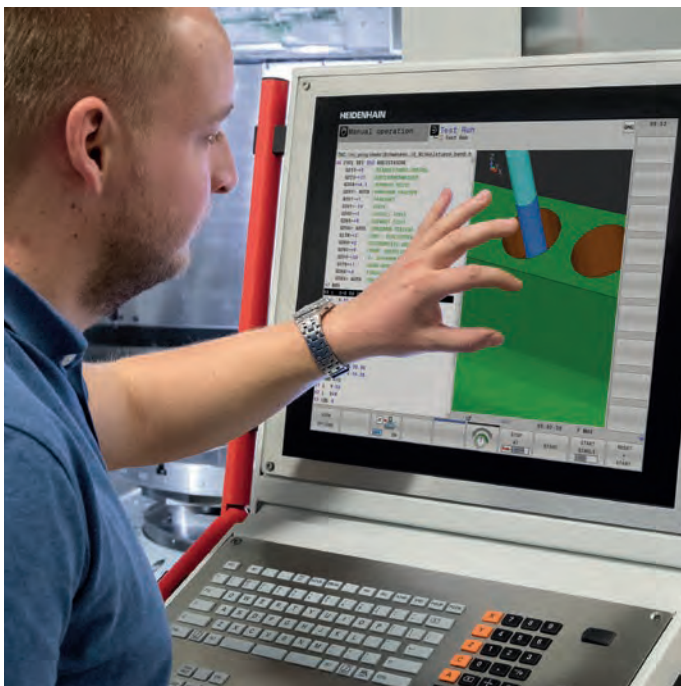

Universally deployable

The TNC 640 is particularly well suited to milling, turning, grinding, HSC, and 5-axis machining on machines with up to 24 axes. The following applications play to its strengths:

Milling-turning machines

- Easy, program-controlled switching capability between milling and turning
- Extensive package of turning cycles
- Constant cutting speed
- Cutter radius compensation

Universal milling machines

- Shop-floor programming in Klartext, the conversational programming language from HEIDENHAIN
- Rapid preset setting with HEIDENHAIN touch probes
- Electronic handwheel capability

High-speed cutting

- Fast block processing
- Short control-loop cycle time
- Motion control with jerk compensation
- High spindle speed
- Fast data transfer

Boring mills

- Drilling and boring cycles
- Drilling of oblique holes
- Control of quills (parallel axes)

Five-axis machining with swivel head and rotary table

- Tilting the working plane
- Cylinder surface machining
- Tool Center Point Management (TCPM)
- 3-D tool compensation
- Fast program execution thanks to short block-processing times

Machining centers and automated machining

- Tool management
- Pallet management
- Controlled preset setting
- Preset management
- Automatic workpiece measurement with HEIDENHAIN touch probes
- Automatic tool measurement and breakage inspection
- Connection with host computer

Grinding operations

- Convenient functions for jig grinding and dressing
- Reciprocating stroke superimposed onto the tool axis
- User-friendly cycles

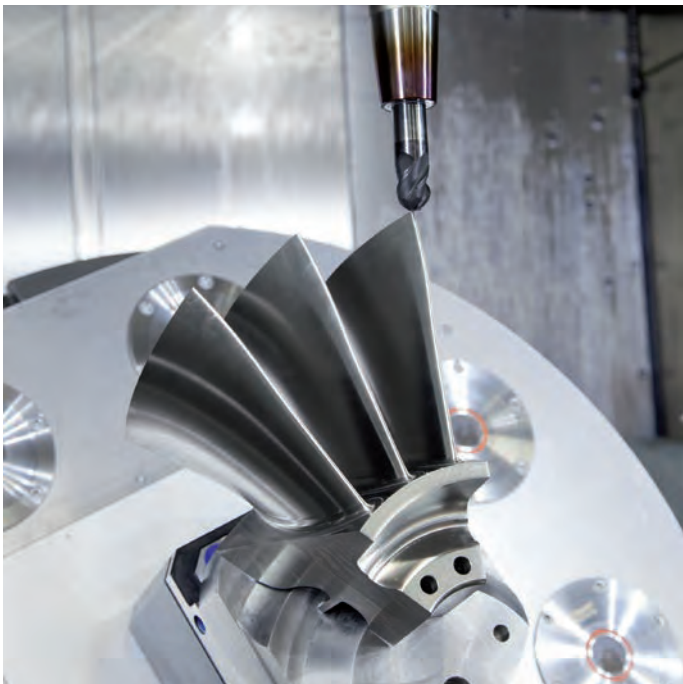

Intuitive and user-friendly

State-of-the-art multitouch operation

Monitor

In a clear format, the 24-inch widescreen displays all of the information you need for programming, operating, and checking the control and the machine, including program blocks, tips, and error messages. **Extended Workspace Compact** offers even more information: alongside the main window with its usual control interface is an additional window for displaying any external application. You can also use a **split screen** in the main window to display your NC blocks on one side and the graphical image and status display on the other. While the program is running, **status displays** are available that inform you about the tool position, current program, coordinate transformations, and more. The TNC 640 even displays the current machining time.

Operating panel

Like all of the TNCs from HEIDENHAIN, the operating panel was designed with the programming process in mind. Program entry is aided by the thoughtful arrangement of keys into **function groups** for programming operating modes, machine operating modes, management/TNC functions, and navigation. Intuitive key assignments, readily understood symbols, and abbreviations unmistakably identify the various functions. The group of keys containing NC Start/Stop and the feed rate/rapid traverse potentiometers let you work through the essential operating sequences in the Program Run, Single Block operating mode with just one hand. This helps you efficiently set up the NC program without losing sight of the machine's workspace. Comments and ISO programs can also be easily entered using the **alphanumeric keypad**. The integrated **machine operating panel** features readily exchangeable snap-on keys permitting easy adaptation to the given machine configuration. HEIDENHAIN also provides significant spatial separation between the axis and spindle potentiometers, which allow you to perform fine motion adjustments. In addition, the operating panel features a complete **set of PC keys** and a **trackball**.

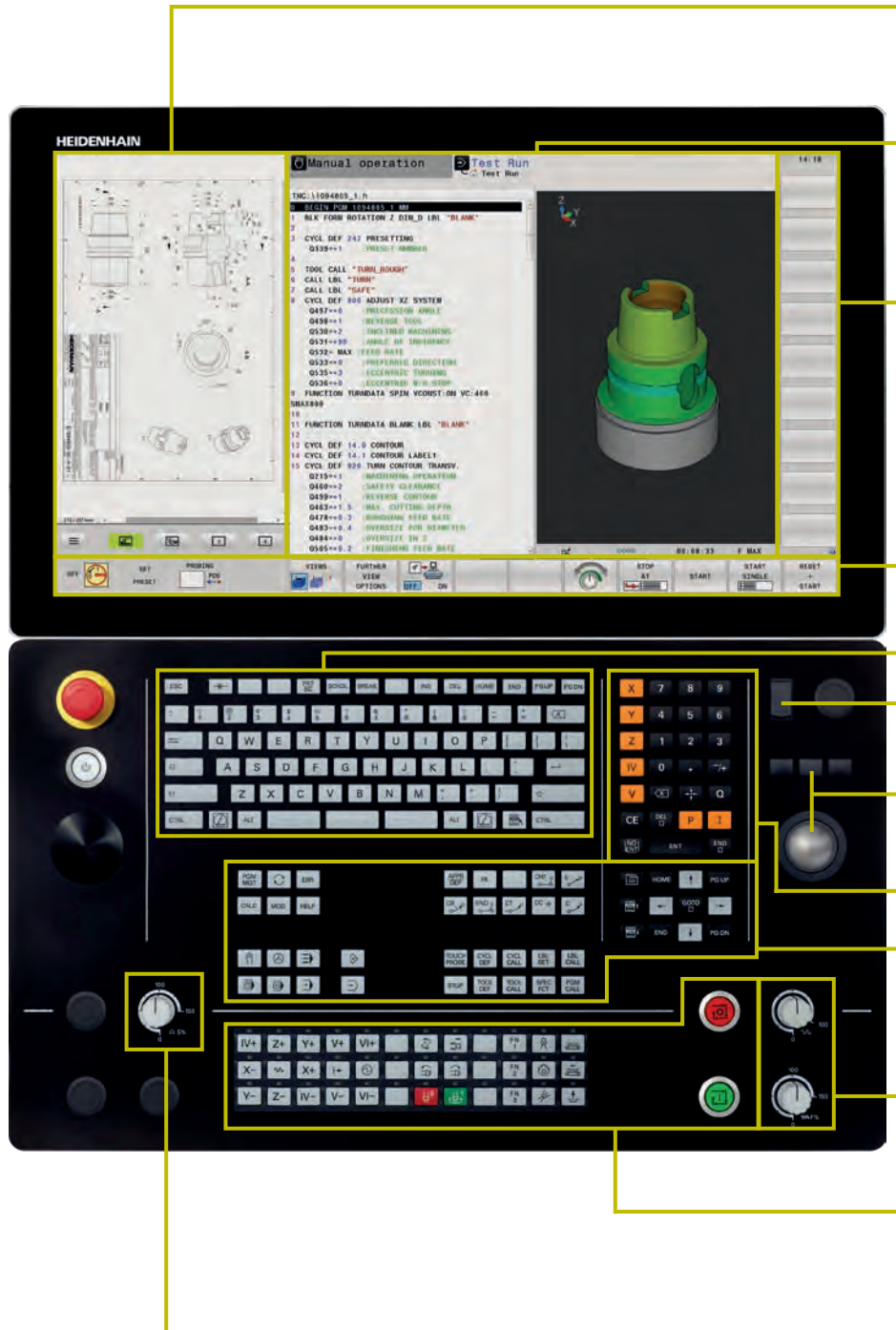

Extended Workspace Compact as an additional window for any external application

Main window for displaying two operating modes, the program, the graphical image, and the machine status

PLC soft keys for machine functions

Self-explanatory **soft keys** for NC programming

Alphanumeric keyboard for comments or ISO programming, and a **set of PC keys** for controlling operating system functions

USB port for additional data storage or other pointing devices

Trackball and mouse buttons for easy operation

Axis-selection keys and **numeric keypad**

Function keys for programming modes, machine operating modes, TNC functions, management, and navigation

Override potentiometers for feed rate and rapid traverse

Machine operating panel with snap-on keys and LEDs

Override potentiometer for spindle speed

Ergonomic and rugged design

The anodized finish on the keyboard unit is highly resilient to chemical and mechanical factors. The engraved keyboard lettering, such as on the potentiometer scale, exhibits high scratch and abrasion resistance.

Intuitive touchscreen operation

The conventional operating approach of the TNC has proven itself over many years, with operators around the world using the TNC's dialog keys, navigation keys, and soft keys. But the touchscreen version of the TNC 640 now supports you with a particularly innovative and user-friendly method of operation. This approach combines the proven benefits of the HEIDENHAIN controls with a new method that uses tapping, swiping, and dragging gestures.

Practical touchscreen











With an IP54 rating, the touchscreen is designed to handle harsh shop conditions thanks to these characteristics:

- Dust-protected
- Splash-proof
- Scratch-proof

To clean your screen, simply select the "Touchscreen Cleaning" mode. This locks the screen to prevent unintended operation.

Gestures for multitouch operation

The screen of the TNC 640 can be operated with gestures like the ones you use on your smartphone or tablet. For example, you can use two fingers to zoom in and out, and swiping lets you quickly navigate through the soft key bar, programs, and menus.

Symbol	Gesture
	Tap
	Double tap
	Long press
	Swipe
	Two-finger drag
	Two-finger drag
	Spread
	Spread
	Pinch
	Pinch

Intuitive and user-friendly

The functional user interface

The key to safe and low-fatigue work is having an intuitive screen layout and an ergonomic, well-arranged keyboard. Although HEIDENHAIN has been adhering to these principles for a long time, the TNC 640 offers a number of features that make working with the control even simpler and easier than before.

Leading-edge design

The user interface of the TNC 640 boasts a sleek outer appearance with gently rounded edges, color gradients, and a pleasingly uniform font. The different screen areas are clearly delineated, and the operating modes are indicated by special operating mode symbols.

To help you evaluate the priority of error messages, the TNC 640 displays them in color-coded categories. A color-coded warning triangle is also displayed.

The smartSelect functions overview

With dialog support, you can now readily select functions that were previously available only via soft key structures. As soon as you open smartSelect, you are shown a tree structure with all of the subordinate functions that can be defined in the control's current operating state. The TNC also displays integrated help on the right-hand side of the smartSelect window. When you make a selection with the cursor or per mouse click, you immediately receive detailed information about the function. The smartSelect feature is also available for the definition of machining cycles, touch probe cycles, and special functions (SPEC FCT), and for parameter programming.

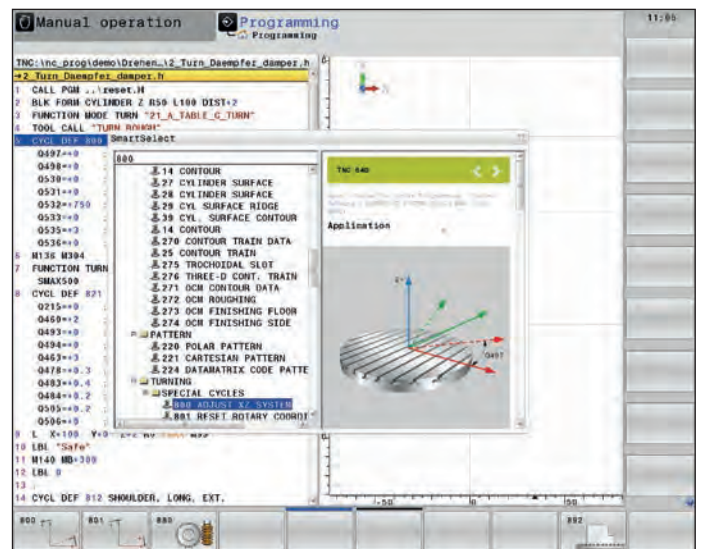
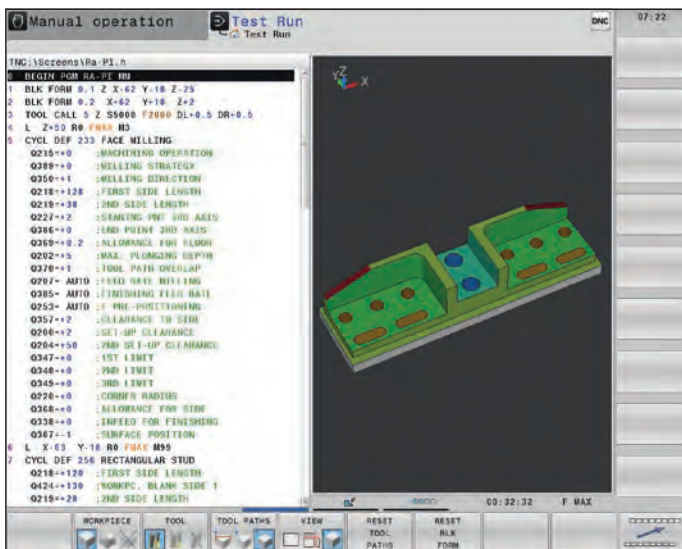

Color-structured programs

The content of a program line can be quite extensive:

- Line number
- Program function
- Input value
- Comment

To make sure you always keep an overview even in complex programs, the TNC 640 displays the individual program elements in different colors. This allows you, for example, to see at a glance where the editable input values are.

Universal table editor

Regardless of whether you are editing a tool, preset, or pallet table, the layout, method of operation, and functions of the table editor are always the same.

Info line

In the info line, the TNC 640 helps you orient yourself by displaying the respective status of the submodule.

MOD function

The additional MOD operating mode offers a wide variety of possible settings in a standardized layout, regardless of the operating mode.

Easy to operate

The TNC 640 can be conveniently operated with a connected mouse, but many machine shops lack an adequate surface for a mouse. A touchscreen, however, eliminates the need for additional workspace for input devices and makes everyday operation of the TNC 640 even easier thanks to swiping, direct selection of operating elements,

and menu navigation. The touchscreen is particularly helpful when using the CAD Import function, allowing you to rapidly zoom, drag, or select with simple gestures.

User administration

The user administration feature of the TNC 640 lets you define various roles and access rights for users, ensuring that each user can act only within his assigned rights. This prevents the unintentional or unauthorized deletion of files or content from system files. In addition, many functions are available only with the proper rights. Consequently, the user administration feature of the TNC 640 not only provides greater data security but also increases machine operating safety.

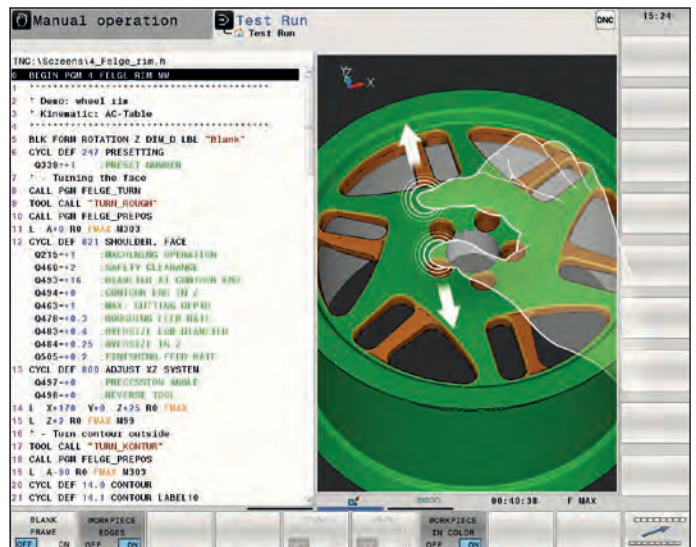
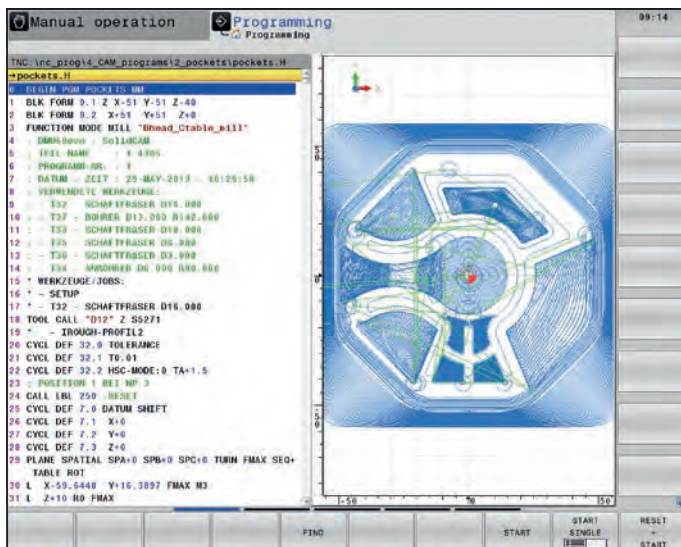

Complete part machining

Milling, turning, and grinding on one machine (option)

Does your workpiece need to be moved to a lathe or grinding machine for additional machining steps after milling? Is all the additional capacity planning, fixture production, workpiece setup, and finished-part inspection a burden? If so, then a TNC 640 on a milling-turning machine can save you a lot of time. With it, you can machine the complete part in one setup using milling, turning, and grinding operations in any sequence desired. And when you're finished, you can measure the finished part inside the machine using a HEIDENHAIN touch probe.

The TNC 640 gives you powerful functions for easily switching between turning, dressing, and milling modes, all from within the NC program. This gives you complete freedom to decide how and when you want to combine the various machining methods. And naturally, the ability to switch between machining modes is independent of the machine and its axis configuration. When switching between modes, the TNC 640 automatically handles all of the internal changes, such as switching to diameter display, setting the preset in the center of the rotary table, and machine-dependent functions such as clamping the tool spindle.*

Programming as accustomed

As always, you can program turning operations with convenient dialog guidance in the HEIDENHAIN Klartext conversational programming language. Besides the standard path functions, you can also leverage FK free contour programming to easily create contour elements not otherwise dimensioned for NC programs. In addition, turning-specific recessing and undercutting contour elements are available and can be defined with informative help illustrations. Even grinding operations can be programmed as usual with HEIDENHAIN Klartext dialog guidance. If the contour is available as a CAD file, then you can easily import it with the aid of the CAD Import function (option).

*The machine must be prepared for this function by the machine manufacturer.

Milling, turning, and grinding cycles

HEIDENHAIN controls have always been known for their comprehensive and technologically advanced package of cycles. The cycles of the TNC 640 include multi-step, frequently recurring operations. While programming cycles, you enjoy dialog guidance and informative help images that illustrate the required parameters. In addition to the well-known TNC milling and drilling cycles, the TNC 640 also provides numerous turning cycles for roughing, finishing, recessing, thread turning, recess turning, and more. These turning functions are based on software from the long-

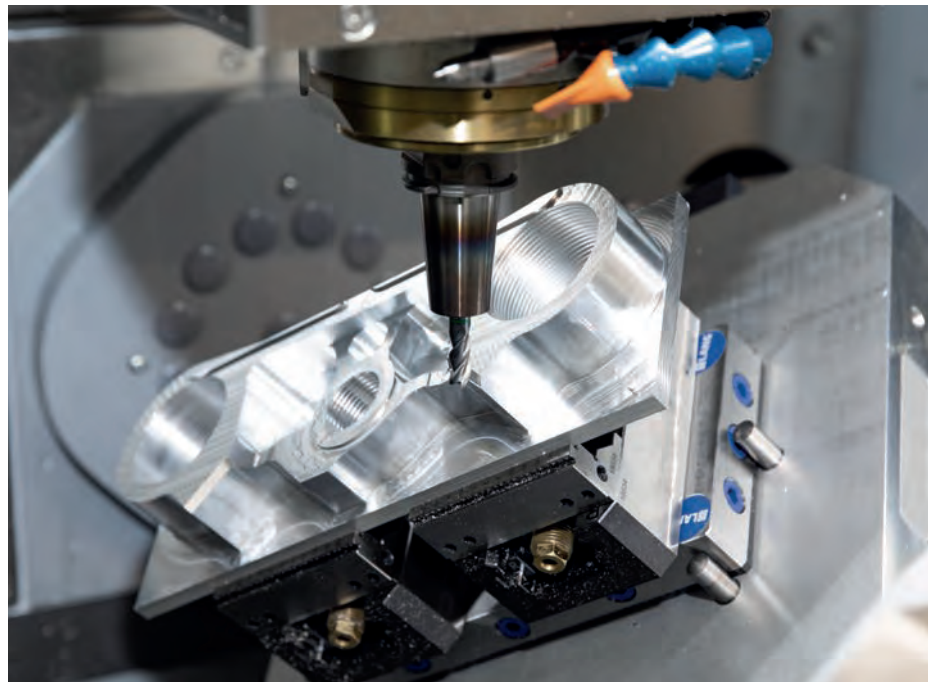

proven HEIDENHAIN turning controls, allowing you to program even complex turning operations with ease on the machine.

The TNC 640's more complex turning cycles employ the same techniques as those used for milling. As a result, TNC programmers can build on their prior knowledge to rapidly enter the world of turning operations on a milling machine without retraining. The control also features grinding cycles, including:

- Define reciprocating stroke
- Activate wheel edge
- Profile dressing

Interpolation turning

Although you can create ring slots, recesses, tapers, or any turning contour using conventional turning operations, you can also take advantage of interpolation turning. In interpolation turning, the tool executes a circular movement using the linear axes. For outside turning, the cutting edge is oriented towards the circle center, and for internal turning, away from the center. By varying the circle radius and the axial position, any rotationally symmetric body can be produced, even in a tilted working plane. The TNC 640 provides two cycles for interpolation turning:

- Cycle 291 activates the coupling of the spindle positions with the axis positions, allowing you to program any desired axial or radial tool movement
- Cycle 292 activates spindle coupling and automatically controls the machining of a programmed turning contour

Turning with a facing slide

A facing slide allows you to perform turning operations on a stationary workpiece, thereby enabling off-center or tilted-plane turning operations. With a facing slide, rotational movement is implemented by the spindle, where an axis integrated into the facing slide determines the extension of the turning tool (facing stroke). With the TNC 640, you don't need to worry about the complex motion involved. You merely select the facing-slide mode with a program command and then program your standard turning cycles as usual. The TNC 640 handles all of the calculations and executes all of the motion sequences on its own.



Fast and reliable machining at high contour fidelity

Dynamic Precision



The TNC 640 is designed for exceptional accuracy and surface quality at high machining speeds, regardless of whether you are milling or turning. A variety of technologies, cycles, and functions operating separately or in concert ensure perfect surface finishes in extremely short machining times:

- Optimized motion control
- Effective jerk reduction
- Dynamic contour look-ahead

The umbrella term **Dynamic Precision** covers a number of HEIDENHAIN cutting solutions that can dramatically improve the dynamic accuracy of a machine tool. These solutions shed new light on the competing demands of accuracy, high surface quality, and short machining times. The dynamic accuracy of machine tools manifests itself in deviations at the tool center point (TCP). These deviations depend on kinetic quantities such as speed and acceleration (including jerk) arising from the vibration of machine components and other factors.

All of these factors contribute to dimensional inaccuracy and the formation of defects on the workpiece surface, thereby impacting both quality and productivity (in the case of quality-related scrap). Dynamic Precision counteracts these problems with intelligent control technology to help improve the quality and dynamic performance of a machine tool. As a result, production time and cost are reduced.

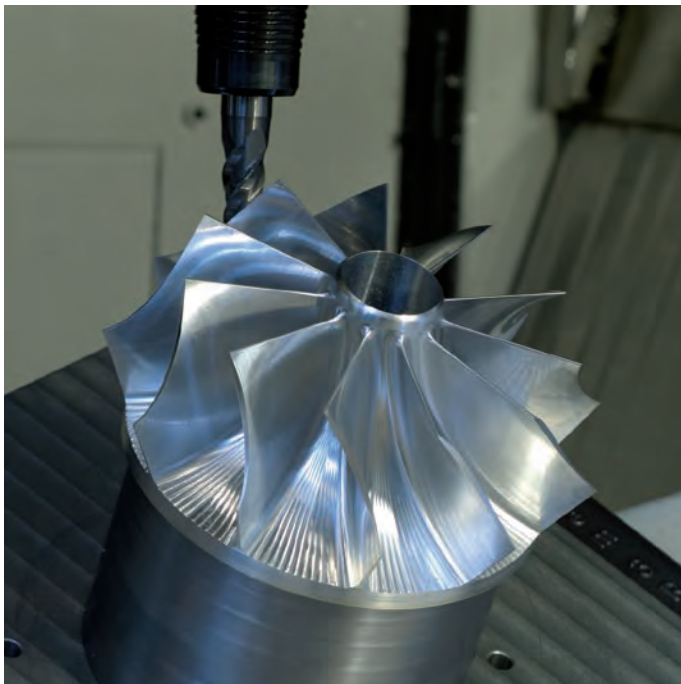

Dynamic Precision contains the following functions, which can be deployed separately or in combination.

Function		Benefits
CTC (Cross Talk Compensation)	Compensation of acceleration-dependent position errors at the TCP	Greater accuracy during acceleration phases
AVD (Active Vibration Damping)	Active damping of machine and motor vibrations	A superior surface finish
CTC + AVD	–	Faster and more accurate machining
PAC (Position Adaptive Control)	Position-dependent adaptation of control parameters	Greater contour fidelity
LAC (Load Adaptive Control)	Load-dependent adaption of control parameters and the maximum axis acceleration	Higher accuracy whatever the load
MAC (Motion Adaptive Control)	Motion-dependent adaptation of control parameters	Less vibration and higher maximum acceleration during rapid traverse

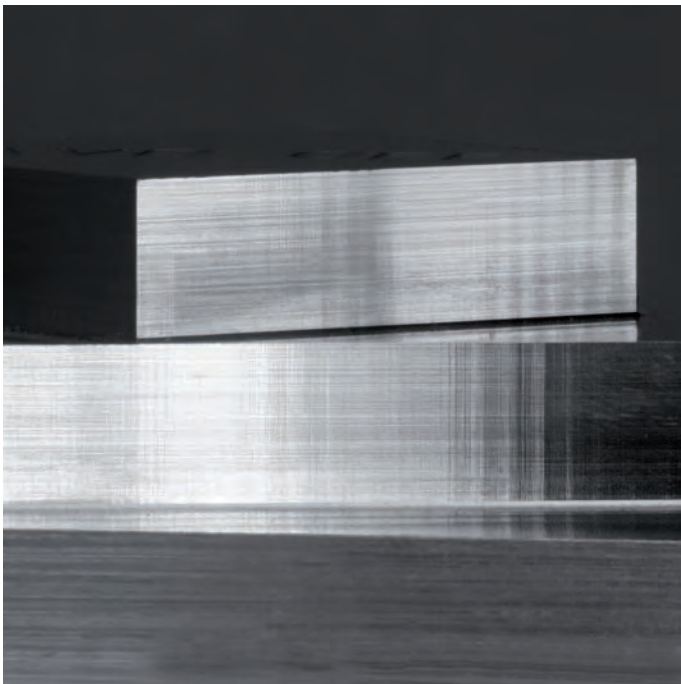

Vibration can significantly impair surface quality.

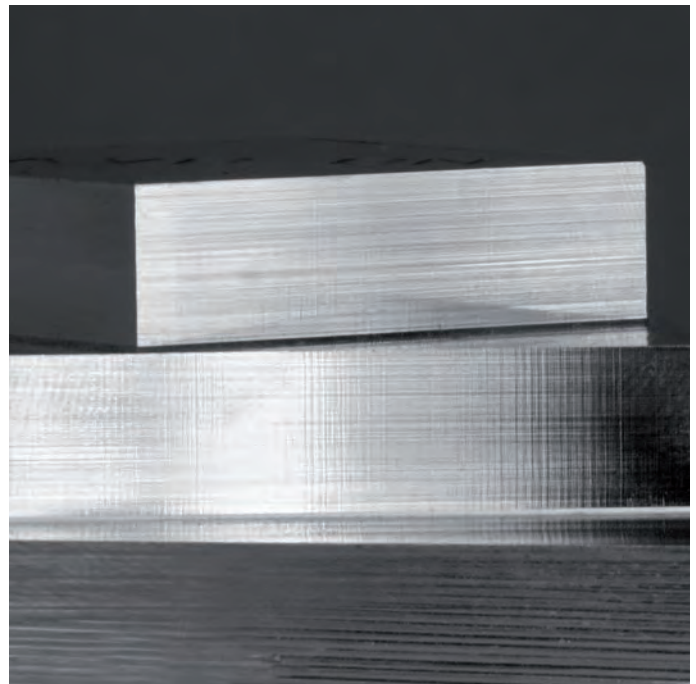

Visibly superior surface quality can be attained with AVD.

Fast and reliable machining at high contour fidelity

Optimal tool guidance by the TNC 640

High contour fidelity and surface quality

TNC controls from HEIDENHAIN are known for their **low-jerk and speed/acceleration-optimized motion control**, enabling optimized surface quality and workpiece accuracy. With the TNC 640, you are able to leverage the latest technological developments. The TNC 640 anticipates and thinks along with you, dynamically calculating the contour ahead of time. In addition, special filters suppress specific machine-specific natural frequencies.

With its **Look Ahead** function, the TNC 640 recognizes directional changes ahead of time and adapts the traversing speed to the shape of the contour and the surface to be machined. You simply program the maximum machining speed as the feed rate and, in **Cycle 32 TOLERANCE**, enter the maximum permissible deviations from the ideal contour. The TNC 640 automatically then adapts the machining operation to the selected tolerance. This method prevents contour defects.

Advanced Dynamic Prediction (ADP)

ADP expands upon the previous look-ahead calculation of the permissible maximum feed rate profile. ADP compensates for differences in the feed rate profiles resulting from the point distribution on neighboring paths, especially in NC programs originating from CAM systems. Among other benefits, this results in particularly symmetrical feed rate behavior on the back-and-forth paths during bidirectional finish milling, as well as very smooth feed rate curves on neighboring milling paths.

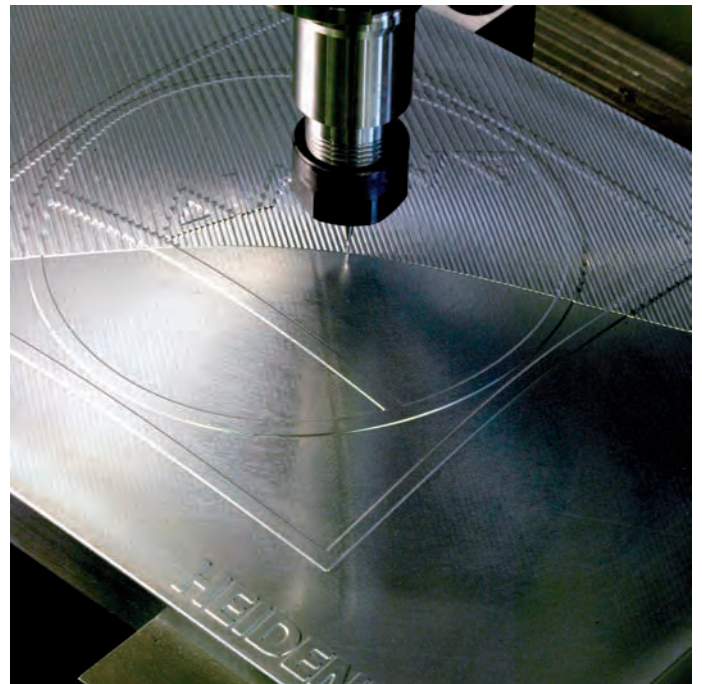
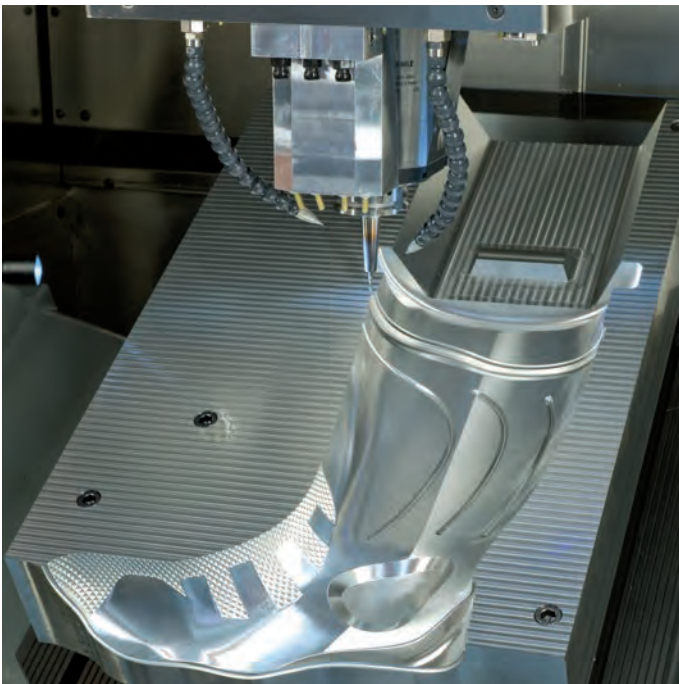

Fast machining and computing processes

With a short block-processing time of at most 0.5 ms, the TNC 640 can run fast look-ahead calculations for optimal use of the machine's dynamic parameters. Functions such as ADP and Look Ahead therefore ensure not only high contour fidelity and surface quality but also optimize the machining time.

One basis for the TNC 640's high speed is its **uniformly digital control design**. This includes the integrated digital drive technology from HEIDENHAIN as well as digital interfaces connecting all of the control components with each other:

- Control components via HSCI (HEIDENHAIN Serial Controller Interface)
- Encoders via EnDat 2.2

As a result, exceptionally high feed rates can be implemented. In the process, the TNC 640 is capable of interpolating up to five axes at the same time. To attain the required cutting speeds, the TNC 640 can digitally control spindle speeds of up to **100000 rpm**.

The TNC 640's powerful 5-axis machining capability even lets you economically manufacture complex 3-D contours. Programs for such contours are usually created offline with CAM systems and typically contain numerous short line blocks that are transferred to the control. With its short block-processing time, the TNC 640 quickly executes even complex NC programs. The control's computing power can handle complex look-ahead calculations in simpler NC programs as well. Thus, regardless of the data volume of the NC programs from your CAM system, the TNC 640 will machine the workpiece to near-perfect conformity with your program.

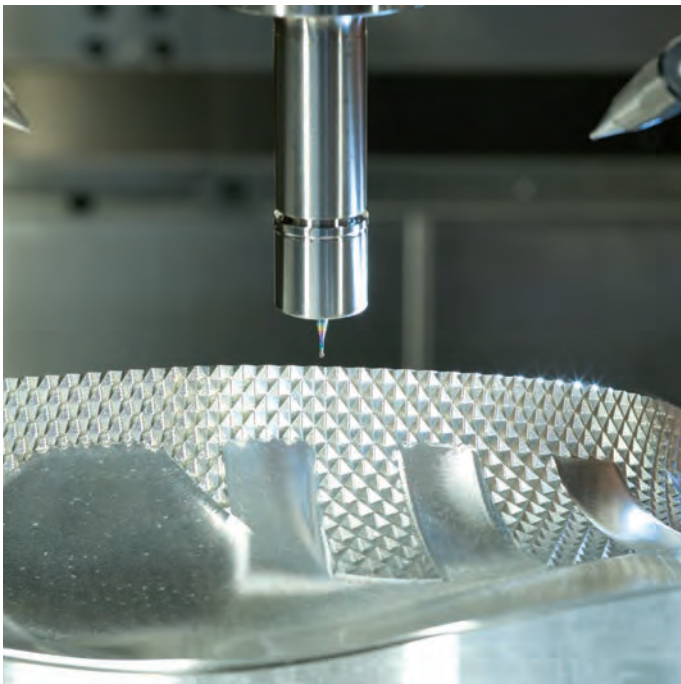

Machining and measuring 3-D contours

Compensating for tool form error

3D-ToolComp (option 92) puts a powerful, three-dimensional tool radius compensation function at your disposal. Angle-dependent delta values describing the deviation of the tool from a perfect circle can be defined in a compensation table (see graphic).

The TNC 640 then corrects the radius value defined for the tool's current point of contact with the workpiece. In order to determine the exact point of contact, the NC program must be created with surface-normal blocks (LN blocks) by a CAM system. The surface-normal blocks specify the theoretical center point of the tool and, if applicable, the tool orientation relative to the workpiece surface.

The optimal procedure is to measure the tool with a laser system and a special cycle, automatically creating a compensation table ready for immediate use by the TNC 640. If the form errors of the tool being used are available in a calibration chart from the tool manufacturer, then you can also create the compensation table manually.

Measuring 3-D geometries

Cycle 444, 3-D probing, allows you to measure points on 3-D geometries. To do so, you enter the coordinates of the measuring point and the associated normal vectors into the cycle. After probing, the TNC automatically calculates whether the measuring points are within a prescribed tolerance. You can request the results via system parameters in order, for example, to initiate a rework operation from within the program. You can also trigger a program stop and a message. After completion of the measurement, the cycle automatically generates a straightforward measurement report in an HTML file. To obtain even more accurate results, you can perform a 3-D calibration of the touch probe prior to running Cycle 444. This cycle then compensates for the touch probe's individual triggering behavior in any direction. Option 92 is required for 3-D calibration.

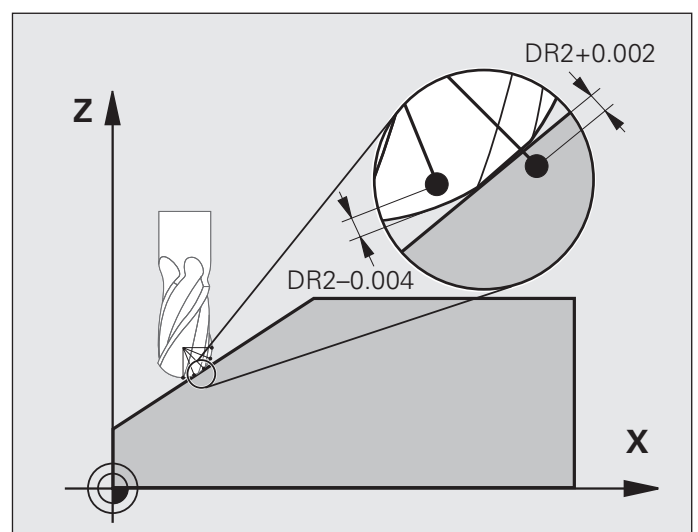

Machining with five axes

Guided tool tip

CAM systems generate 5-axis programs using a postprocessor. In principle, such programs contain either all of the coordinates of the machine's existing NC axes, or they contain NC blocks with surface normal vectors. During 5-axis machining on machines with three linear axes and two additional tilting axes,* the tool is always kept perpendicular to the surface of the workpiece or is tilted at a specific angle relative to it (inclined tool machining).

Regardless of what type of 5-axis programs you wish to run, the TNC 640 performs all of the compensating movements in the linear axes arising from movements in the tilting axes. The TNC 640's **TCPM function** (Tool Center Point Management), an improvement upon the proven TNC function M128, provides optimal tool guidance and prevents contour gouging.

* The machine and TNC must be adapted for these functions by the machine manufacturer.

With TCPM, you can define the behavior of the tilting and compensating movements that are automatically calculated by the TNC 640:

TCPM defines the interpolation between the start and end positions:

- **Face Milling:**
In face milling, primary cutting is performed using the front face of the tool (or the corner radius in the case of toroid cutters). In the process, the tool center point moves along its programmed path.
- **Peripheral Milling:**
In peripheral milling, primary cutting is performed with the lateral surface of the tool. The tool tip also travels along its programmed path, but machining with the circumference of the tool results in a clearly defined plane. As a result, peripheral milling is well suited for the production of precise surfaces using gear hobbing processes.

TCPM defines the **effect of the programmed feed rate** with two possibilities to choose from:

- The actual speed of the tool tip relative to the workpiece: in the case of large compensating movements while machining close to the center of tilt, very high axis feed rates may arise.

- Contouring feed rate of the axes programmed in the respective NC block: the feed rate is generally lower, but you attain better surface quality with large compensating movements.

In order to achieve better surface quality, an **inclination angle** is often configured for contour machining, with corresponding angle values in the NC program. The effect of the inclination angle can also be configured via TCPM:

- Angle of inclination defined as an axis angle
- Angle of inclination defined as a spatial angle

The TNC takes the inclination angle into account in all 3-D machining operations, including with 45° swivel heads or tilting tables. You can specify the angle of inclination in the NC program via a miscellaneous function or manually set it with an electronic handwheel. The TNC 640 ensures that the tool remains on the contour and does not damage the workpiece.

You can use Cycle 444 to measure 3-D geometries even when TCPM is active. The TNC 640 then automatically takes the inclination angle of the touch probe into account.

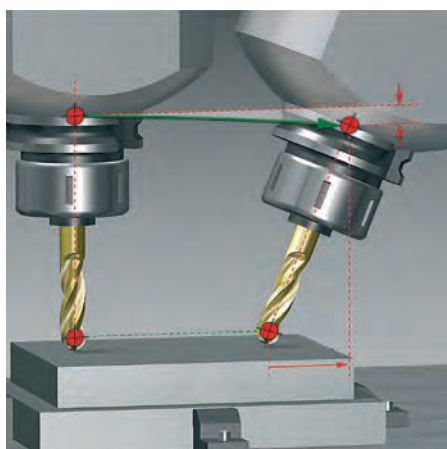

Face milling

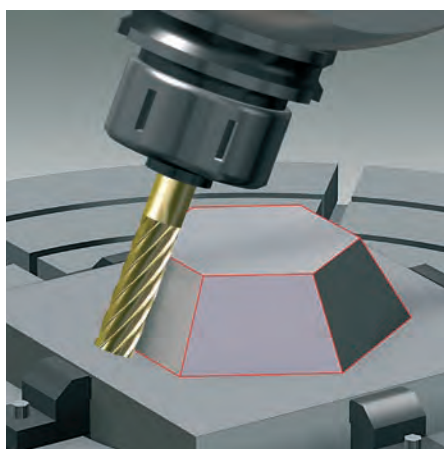

Peripheral milling

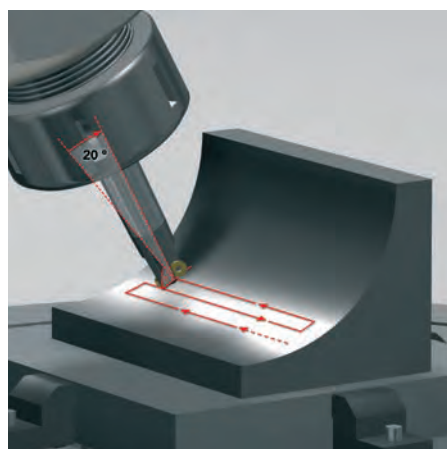

Inclined-tool machining

Machining with five axes

Swivel head and rotary table controlled by the TNC

Many five-axis operations that initially appear to be highly complex can be broken down into common 2-D movements that have been tilted about one or more rotary axes or wrapped around a cylindrical surface. In order for you to create and edit such problems quickly and easily without a CAM system, the TNC supports you with helpful functions.

Tilting the working plane*

Programs for contours and holes on inclined surfaces are often extremely complex and require time-consuming computing and programming work. But the TNC 640 can save you a great deal of programming time.

You simply program the machining operation as usual in a plane, such as the XY plane; the machine then performs the operation in a tilted plane.

The PLANE function makes it easy for you to define a tilted working plane: tilted working planes can be specified in seven different ways depending on the information available in the workpiece drawing. Help images support you during program entry.

You can also use the PLANE function to define the positioning behavior during tilting to avoid unpleasant surprises when the program is run. The settings for defining the positioning behavior are identical for all PLANE functions, making operation much easier.

* The machine and TNC must be adapted for these functions by the machine manufacturer.



Cylinder surface machining*

Programming contours made up of straight lines and circles on cylindrical surfaces for rotary tables is no problem with the TNC 640. You simply program the contour in the plane of an unrolled cylinder surface. The TNC 640 then performs the machining operation on the cylindrical surface of the cylinder.

The TNC 640 features four cycles for cylindrical surface machining:

- Slot milling (the slot width is the same as the tool diameter)
- Guide-groove milling (the slot width is greater than the tool diameter)
- Ridge milling
- Outside contour milling

* The machine and TNC must be adapted for these functions by the machine manufacturer.

Manual axis motion in the tool direction on 5-axis machines

Tool retraction is very important in five-axis machining. The virtual tool axis function provides assistance by allowing you to move the tool in the direction of the tool axis using external direction keys or a handwheel. This function is especially useful if you want to

- retract the tool in the direction of the tool axis during an interruption of a 5-axis machining program,
- use the handwheel or external direction keys to perform an operation in Manual mode with an inclined tool, or
- move the tool with the handwheel in the active tool axis direction during machining.

Feed rate for rotary tables in mm/min*

By default, the feed rate of rotary axes is programmed in degrees/min. However, the TNC 640 can interpret this feed rate in mm/min as well. The feed rate at the contour is then independent of the distance of the tool center point from the center of the rotary axis.

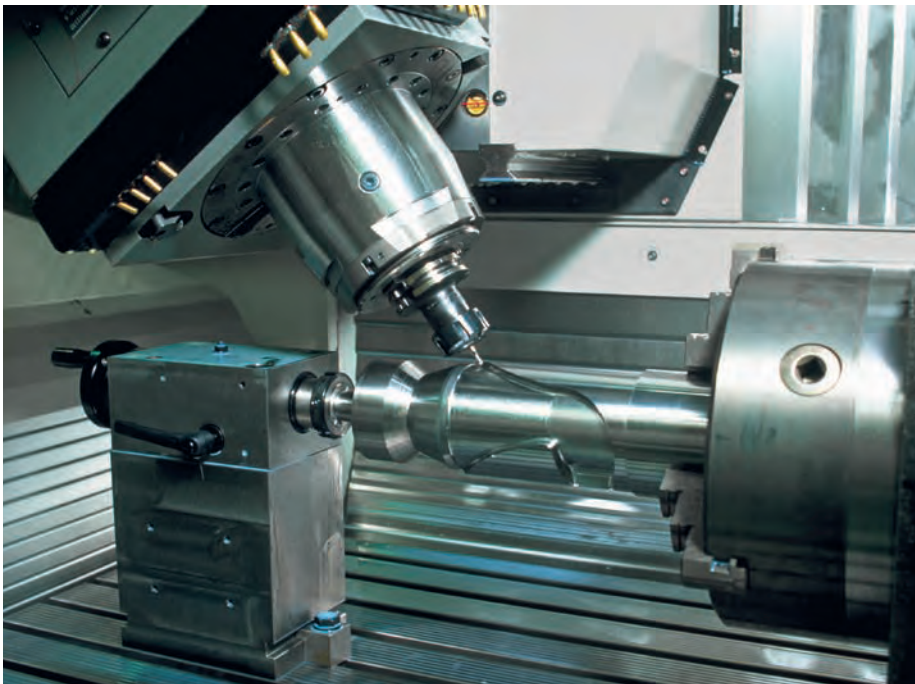

Intelligent machining

Dynamic Collision Monitoring option (DCM)

The complex machine movements and the generally high traversing speeds involved in 5-axis machining make axis movements difficult to predict. This makes collision monitoring a valuable function that gives the machine operator peace of mind and protects the machine from damage.

NC programs from CAM systems may be able to avoid collisions of the tool or tool holder with the workpiece but do not account for machine components in the workspace—unless you invest in expensive offline machine simulation software. But even then, there is no guarantee that the arrangement of machine components still matches the simulation. In the worst case scenario, collisions won't manifest themselves until the part is actually machined.

For cases such as these, the **Dynamic Collision Monitoring (DCM)*** feature of the TNC 640 provides the machine operator with peace of mind. The control interrupts machining whenever a collision is imminent, thus increasing safety for both the machine and operator. This, in turn, helps prevent machine damage and any resulting costly downtime. Unattended shifts also become more reliable.

Dynamic Collision Monitoring (DCM) even works in both **automatic mode** and **manual operation**. If the machine operator is on a "collision course" during workpiece setup, for example, then the TNC 640 will detect the impending collision and stop the axis with an error message.

* The machine and TNC must be adapted for these functions by the machine manufacturer.

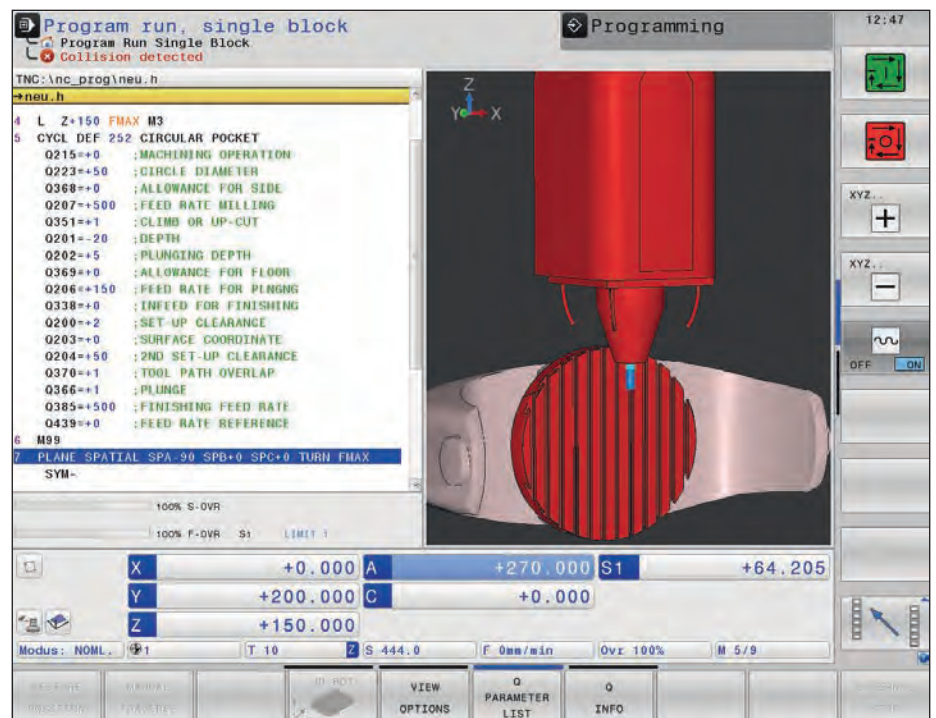

Of course, the TNC 640 also shows the operator which machine components are on a path toward collision, both in the error message and in a graphical depiction. If a collision warning is displayed, then the TNC 640 permits retraction of the tool only in directions that will increase the clearance between the colliding objects.

The machine manufacturer defines the machine components by using geometric bodies to describe the workspace and the collision objects. For tilting devices, the machine manufacturer can also use the description of the machine kinematics to define the collision objects.

A new 3-D file format for collision objects offers further appealing benefits:

- Convenient data transfer of standard 3-D file formats
- Fully detailed illustration of machine components
- Greater exploitation of the machine's workspace

The TNC 640 can also monitor tool carriers such as holders for milling cutters or touch probe housings. To this end, a tool-carrier kinematic model is assigned to the tool in the tool table. When the tool is inserted, the respective tool carrier is activated in the collision monitoring function.

Because the machine design itself prevents collisions between certain machine components, not all of the machine parts require monitoring. For example, a

HEIDENHAIN TT tool touch probe clamped to a machine table for tool measurement will never collide with the machine cabin. The machine manufacturer can therefore specify which machine elements could collide with each other.

When using the Dynamic Collision Monitoring, please note the following:

- DCM can help reduce the danger of collision, but DCM cannot completely prevent all collisions.
- Only the machine manufacturer can define machine components.
- Collisions between machine components (such as a swivel head) and the workpiece cannot be detected.
- DCM cannot be used in servo-lag operation (no feedforward).
- DCM cannot be used for eccentric turning.

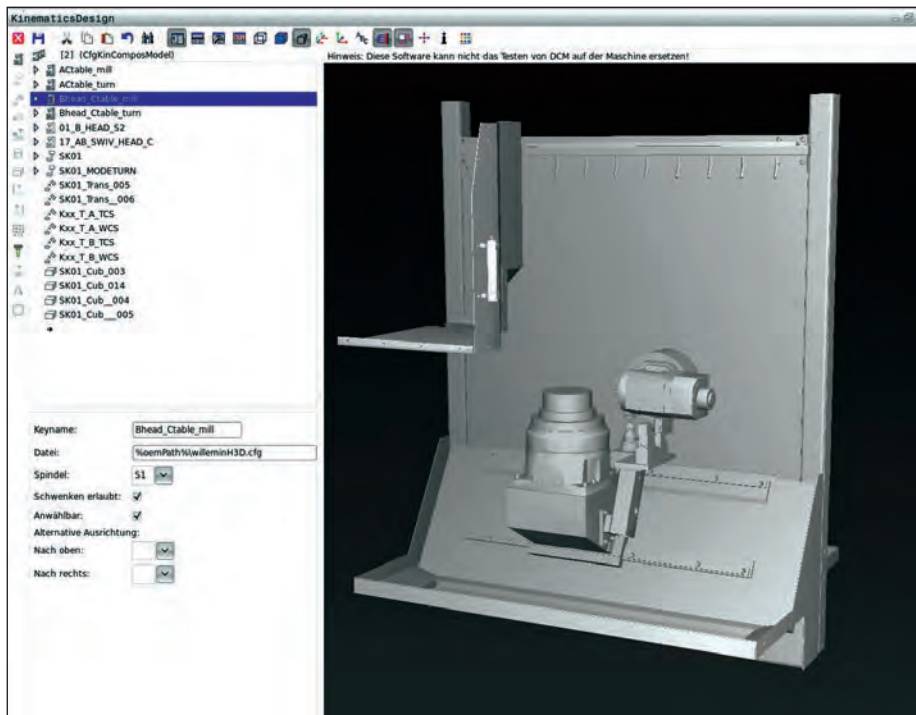

Intelligent machining

Dynamic Efficiency

dynamic + efficiency

Under the rubric of **Dynamic Efficiency**, HEIDENHAIN offers innovative TNC functions that help the user make heavy machining more efficient and improve process reliability. These software functions not only support the operator but also make production processes faster, more reliable, and more predictable—in other words, more efficient. Dynamic Efficiency permits higher removal rates and therefore increases productivity without making the user resort to special tools. At the same time, it prevents tool overloading and premature cutter wear. Dynamic Efficiency makes your manufacturing overall more economical while increasing process reliability.

Dynamic Efficiency encompasses four software functions:

- **Active Chatter Control (ACC)** is an option for reducing chatter tendencies and permits higher infeeds
- **Adaptive Feed Control (AFC)** is an option for regulating the feed rate based on the machining situation
- **Trochoidal milling** is a function for tool- and machine-friendly roughing of slots and pockets
- **OCM (Optimized Contour Milling)** is an option for tool-friendly machining of any pocket and island under consistent process conditions

Each solution by itself delivers key benefits for the machining process. When combined, these TNC functions optimally exploit the potential of both machine and tool while reducing the mechanical load. They also prove their worth under changing machining conditions, such as interrupted cuts, varying plunging processes, or simple roughing operations. In practice, removal rate increases of **20 to 25 percent** are possible.

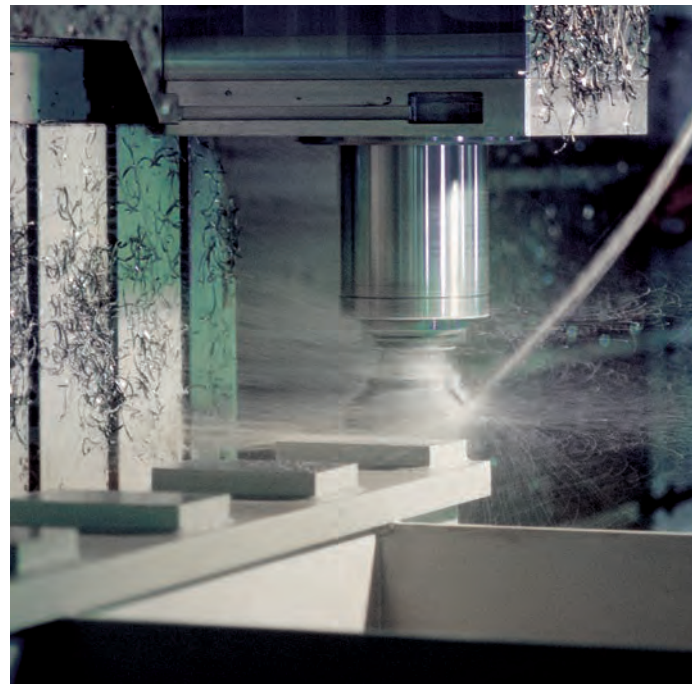

Active Chatter Control option (ACC)

dynamic + efficiency

Roughing operations (power milling) give rise to strong milling forces. Depending on the rotational speed of the tool, the resonances in the machine tool, and the material removal rate during milling, the tool may begin to "chatter." Chatter puts the machine under heavy strain and causes blemishes on the workpiece surface. Tool wear is also accelerated and less evenly distributed. In extreme cases, the tool may even break.

To reduce chatter susceptibility, HEIDENHAIN now offers a highly effective optional control function called Active Chatter Control (ACC). This option is particularly beneficial during heavy machining:

- Improved cutting performance
- Higher removal rates (up to 25 % and more)
- Lower forces on the tool, with increased tool life
- Less strain on the machine



Heavy machining without ACC (upper image) and with ACC (lower image)



Intelligent machining

Adaptive Feed Control option (AFC)

dynamic + efficiency

HEIDENHAIN controls have always allowed the operator to enter the feed rate for each block or cycle and also manually adjust the feed rate to the actual machining situation using an override potentiometer. But this approach relies on the experience of the operator and requires him to be at the machine.

Adaptive Feed Control (AFC) automatically regulates the feed rate of the TNC, taking into consideration the given spindle power and other process data. The TNC first records the maximum spindle power during a teach-in cut. Before machining, you can then use a table to define the limit values between which the TNC is allowed to influence the feed rate while in "regulating" mode. You can flexibly choose among various overload reactions that have been defined by the machine manufacturer. Adaptive Feed Control (AFC) offers a series of benefits:

Process reliability

Roughing at high material removal rates involves strong cutting forces, which in practice can cause tool defects. If the user is unable to react quickly, perhaps because he is responsible for multiple machines or because the shift is unattended, then significant secondary damage and cost may be incurred:

- Costly rework on the workpiece
- Irreparable workpiece damage
- Damage to the tool holder
- Machine downtime due to spindle damage

Continuous monitoring detects any increase in spindle power due to tool wear or defective inserts, and a replacement tool can be automatically inserted.* In this manner, AFC prevents potential secondary damage due to tool wear while increasing process reliability.

Reduced machining time

AFC regulates the feed rate of the TNC based on the given spindle power. In machining areas requiring less material removal, the feed rate is appropriately increased. This can significantly reduce the machining time.

Gentler on the machine

When the maximum teach-in power is exceeded, the feed rate is reduced down to the reference spindle power. As a result, the machine undergoes less strain, and the main spindle is protected from overloading.

*The machine must be adapted for this function by the machine manufacturer.

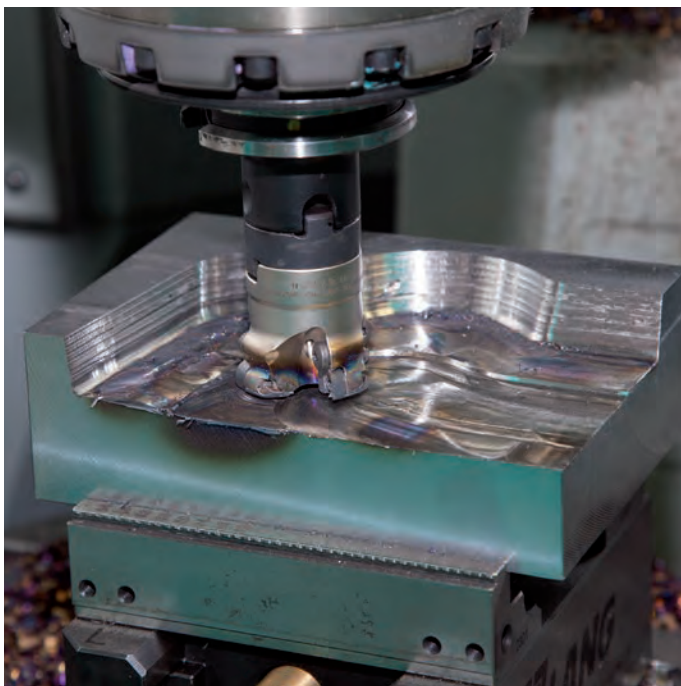

Workpiece with secondary damage resulting from a broken indexable insert

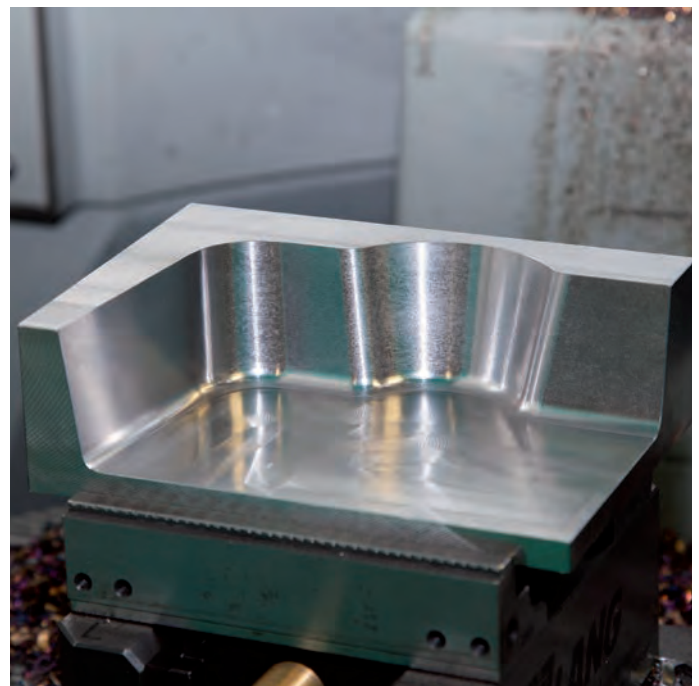

Fully machined workpiece protected by AFC

Machine any contour slot with trochoidal milling

dynamic + **efficiency**

The ability to machine any slot at high efficiency from start to finish is the key benefit of trochoidal milling. In trochoidal milling, roughing is performed with forward linear motion superimposed onto circular strokes. It is often used on high-strength or hardened materials that would otherwise require low infeeds due to the high loads on both tool and machine.

Thanks to the special cutting motion used in trochoidal milling, however, there are no added wear-inducing influences on the tool, and higher infeeds are possible. During hobbing, the entire cutting edge can be used as well. You thereby attain a higher material removal rate per tooth. Circular motion plunging into the material exerts less radial force on the tool. This reduces the mechanical load on the machine and prevents vibration. Enormous time savings can be realized by combining this milling method with the integrated Adaptive Feed Control (AFC) option.

The slot to be machined is described in a contour subprogram as a contour train. You define the dimensions of the slot and the cutting data in a separate cycle. Any residual material can then be easily removed with a subsequent finishing cut.

The main benefits are as follows:

- Contact over entire cutter length
- Higher removal rates
- Less strain on the machine
- Less vibration
- Integrated finishing of the side wall
- Superior chip removal

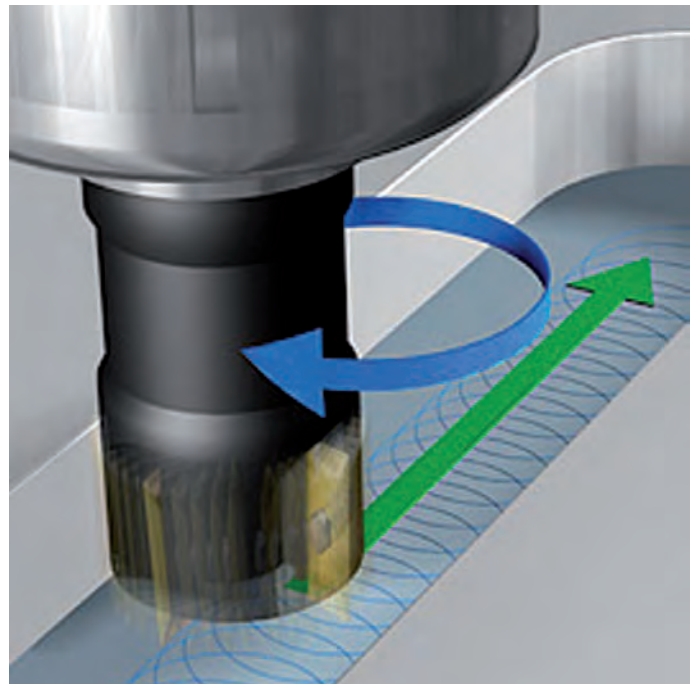

Intelligent machining

Optimized roughing processes with OCM (option)

dynamic + efficiency

Efficient machining strategies are a key basis for economical NC manufacturing. Roughing processes, in particular, offer great potential for optimization. This is because roughing steps usually take up a sizeable portion of the overall machining time.

With OCM, you can rough out any pocket and island with high process reliability and lower tool wear thanks to highly consistent process conditions. You simply program the contour as usual directly in the Klartext conversational programming language or utilize the convenient CAD Import function. The control then automatically calculates the complex movements required for attaining consistent process conditions.

Advantages of OCM over conventional machining:

- Reduced thermal load on the tool
- Superior chip removal
- Consistent tool contact conditions
 - Higher cutting parameters
 - Higher material removal rate

OCM is an effective, reliable, and convenient way to improve your productivity:

- Perform shopfloor programming for any pocket or island
- Notably higher machining speed
- Considerable reduction in tool wear
- More chips in less time

The OCM option contains practical cycles for roughing, side-wall finishing, and floor finishing.

Conventional machining

S5000, F1200, a_p : 5.5 mm

Overlap factor: 5 mm

Machining time: 21 min 35 s

Tool: VHM end mill \varnothing 10 mm
Workpiece material: 1.4104

Machining with OCM

S8000, F4800, a_p : 22 mm

Overlap factor: 1.4 mm

Machining time: 6 min 59 s

Tool: VHM end mill \varnothing 10 mm
Workpiece material: 1.4104

In the following machining example, both the machining time and the tool wear were reduced **by a factor of three**.



Tool after two parts



Tool after six parts

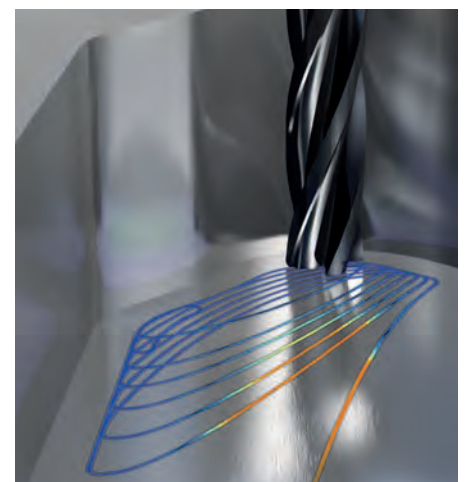

Intelligent machining

Global Program Settings (option)

The Global Program Settings option is used especially for the production of large molds. It is available in the Program Run operating modes and in MDI mode. This option allows you to perform a variety of coordinate transformations and settings, and then apply them globally to a selected NC program without actually modifying it.

You can even change the Global Program Settings mid-program during a program stop using a handy fillable form. When the program is started, the TNC 640 moves to a new position as needed in accordance with a positioning logic that you have defined.

The following functions are available:

- Additional, additive datum shift
- Superimposed mirroring
- Handwheel superimpositioning, with axis-specific memory of the paths covered by the handwheel, including in a virtual axis direction
- Superimposed basic rotation
- Superimposed rotation
- Globally valid feed-rate factor
- Mirroring of axes

Handwheel superimpositioning is possible in various coordinate systems:

- Machine coordinate system
- Workpiece coordinate system (active basic rotation is taken into account)
- Tilted coordinate system

You can select the desired coordinate system in a handy fillable form.

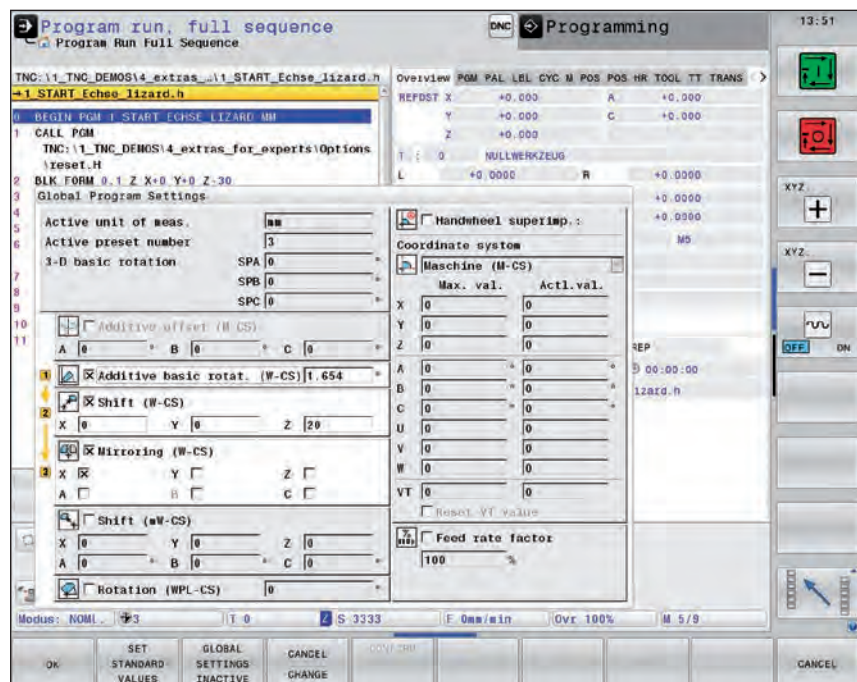

Automated machining

The TNC 640 measures, manages, and communicates

The requirements gap between machining centers and typical tool and moldmaking machines is becoming ever narrower. Of course, the TNC 640 is also very capable of controlling automated manufacturing processes. It features the necessary functionality to initiate the proper machining operation in concatenated machining scenarios with individual workpieces in any workholding arrangement.

Inspecting workpieces for proper machining and dimensional accuracy

The TNC 640 features a number of measuring cycles for checking the geometry of the machined workpieces. This requires inserting a touch probe from HEIDENHAIN into the spindle in place of the tool (see page 50). The resulting functionality allows you to do the following:

- Recognize a workpiece and call the appropriate part program
- Check whether all machining operations were conducted correctly
- Determine infeeds for finishing
- Detect and compensate for tool wear
- Check the workpiece geometry and classify parts
- Log measured data
- Ascertain the machining error trend
- Check whether tolerances were maintained, and configure various reactions, such as an error message

Milling cutter measurement and automatic tool data compensation

In conjunction with the TT tool touch probe (see page 51), the TNC 640 lets you automatically measure milling tools in the machine. The TNC 640 then stores the determined values, such as tool length and radius, in its tool memory. By inspecting the tool during machining, you can quickly detect wear or breakage for preventing scrap and rework. If the measured deviations are out of tolerance, or if the monitored tool life is exceeded, then the TNC 640 locks the tool and automatically inserts a replacement tool.

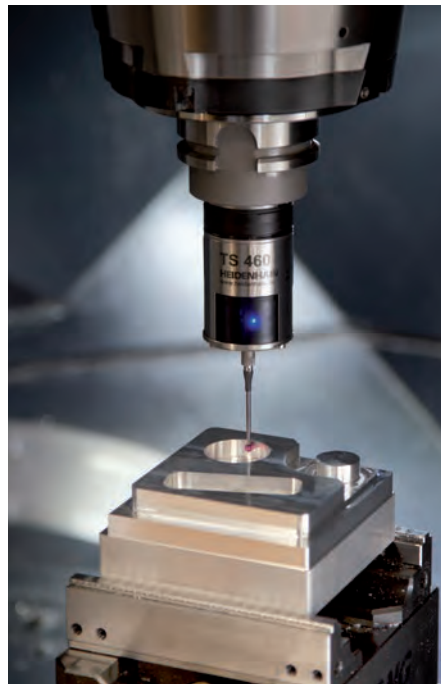

Pallet management and serial machining

Pallet management

Pallet management functionality lets you automatically machine workpieces in any order. Upon insertion of the pallet, the correct machining program and preset are automatically selected. You can also apply coordinate transformations and measuring cycles in the part programs.

Batch Process Manager (option)

Batch Process Manager is a powerful function for pallet machining and serial production. With its intuitive user interface, you can plan your production process and receive important information about upcoming machining operations.

Batch Process Manager automatically checks for missing tools, insufficient tool life, and any required manual tool changes. The results of this check are displayed in the status overview.

Batch Process Manager displays the following information in advance:

- The sequence of operations
- The time of next manual intervention
- The program duration and run time
- Status information about the preset, tool, and program

In Program Run mode, you also have the option of using soft keys to perform a collision check for all pallet subprograms with active collision checking (possible only with software option 40 (DCM)).

Tool-oriented machining

In tool-oriented machining, a single machining step is performed on all of a pallet's workpieces before moving to the next machining step. This keeps the number of tool changes to a minimum and significantly shortens the machining time.

The TNC 640 supports you with convenient fillable forms that allow you to assign a tool-oriented operation to a pallet with multiple workpieces. As always, you still write the machining program in the normal workpiece-oriented sequence.

You can also use this function even if your machine does not support pallet management. In this case, you simply define the position of the workpiece on the machine table in the pallet file.

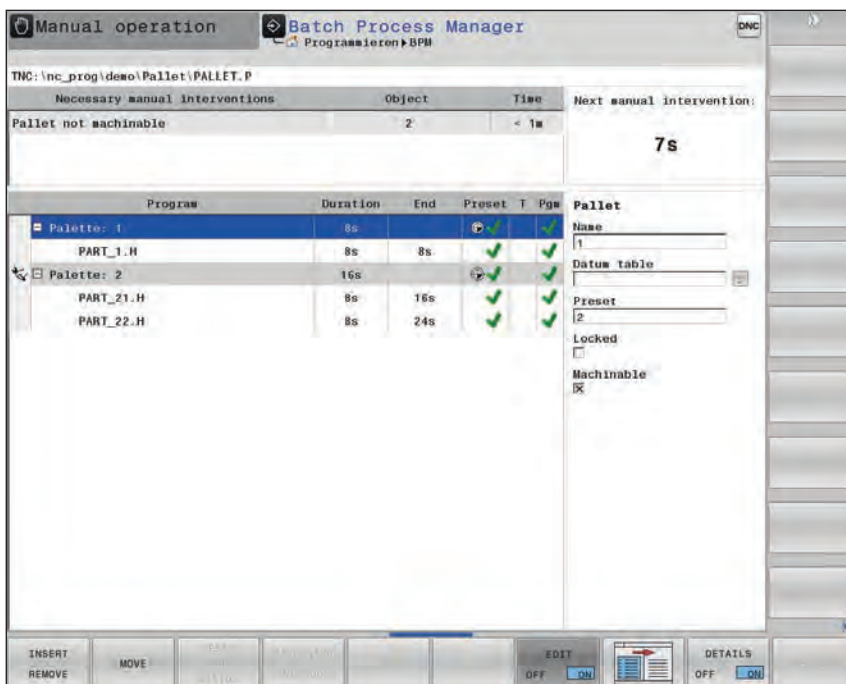

Tool management and workspace monitoring

Tool management

For machining centers with an automatic tool changer, the TNC 640 offers a central tool memory area for numerous milling, grinding, dressing, and turning tools. This tool memory area is a freely configurable file that can be optimally adapted to your needs. You can even have the TNC 640 manage your tool names. The control prepares the next tool change while the current tool is still cutting. This significantly reduces the non-cutting time required for tool changes.

With the Expanded Tool Management option, the control shows only the required input fields regardless of the selected tool type. Any data can also be graphically depicted.*

* The machine must be adapted for this function by the machine manufacturer.

Workspace monitoring

With the Visual Setup Control (VSC) option, the TNC can automatically monitor the current setup or machining situation during program run. This option uses a camera system to take reference photos of the first parts in a series in order to then compare them with photos of subsequent parts.

User-friendly cycles let you specify multiple locations within the NC program at which the control should perform a visual comparison of the nominal-to-actual condition. If an error is detected, the TNC reacts in a manner selected by the user. VSC not only helps you avoid expensive damage to the tool, workpiece, and machine, but it also lets you identify missing machining operations or document recurring setup configurations.

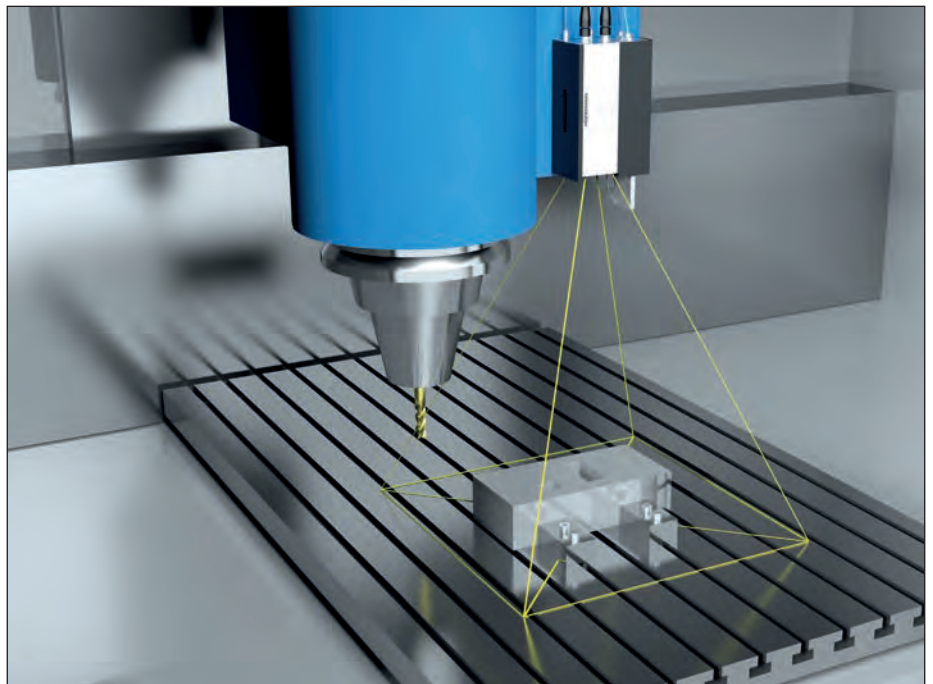

Minimize setup times

The TNC 640 makes setup easy

Before machining can begin, the workpiece must first be clamped, the machine must be set up, the position of the workpiece in the machine must be determined, and the preset must be set. This is a time-consuming but indispensable procedure because any error directly reduces the machining accuracy. Particularly in small and medium-sized production runs, as well as in the case of very large workpieces, setup times become a significant factor.

The TNC 640 features application-oriented, real-world setup functions that support the user, help reduce non-productive time, and enable overnight, unattended production. In conjunction with the **touch probes**, the TNC 640 offers numerous probing cycles for automatic workpiece setup, setting the preset, and measuring workpieces and tools.

Fine manual axis control

During setup, you can use the axis-direction keys to move the machine axes manually or with an incremental jog. A simpler and more reliable way, however, is to use electronic handwheels from HEIDENHAIN (see page 53). With these handwheels, you are always close to the action, enjoy a close-up view of the setup process, and can control the infeed responsively and precisely.

Adapting the probing velocity

In many cases, the workpiece must be probed at unseen positions or in cramped spaces, and the standard probing feed rate is usually too fast for this. In such situations, you can use the override knob to change the feed rate during probing without affecting the accuracy.

Workpiece alignment

Touch probes from HEIDENHAIN (see page 50) and the probing functions of the TNC 640 keep you from having to perform time-consuming workpiece alignment:

- You start by simply clamping the workpiece in any position.
- The touch probe then ascertains the actual workpiece position by probing a surface.
- The TNC 640 subsequently compensates for the misalignment by performing a "basic rotation," in which either the NC program is executed at the ascertained angle of rotation or the rotary table is turned in order to correct the misalignment.
- The TNC 640 offers manual, automatic, and semiautomatic cycles for compensating for misalignments in two or three dimensions

Compensating for workpiece misalignment
by rotating the coordinate system or turning the table

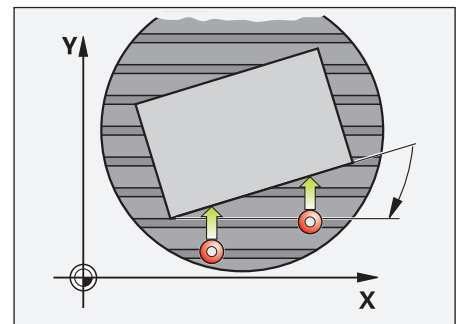
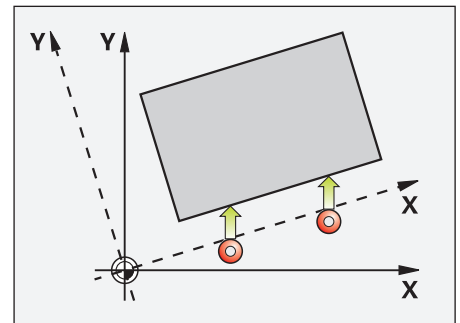

Setting presets

A preset allows you to assign a defined value displayed by the TNC to any position on the workpiece. Finding this point quickly and reliably reduces non-productive time and increases machining accuracy.

The TNC 640 features probing cycles for automatically setting presets. Ascertained presets can be saved as follows:

- Using the preset management
- In a datum table
- Through direct setting of the display

Setting a preset

on a corner, for example, or in the center of a circular stud

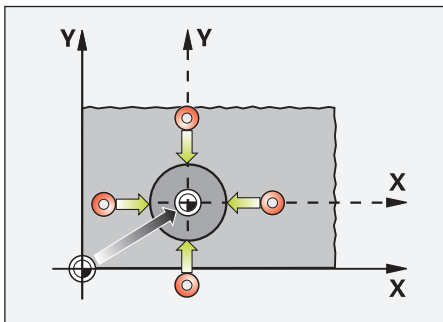
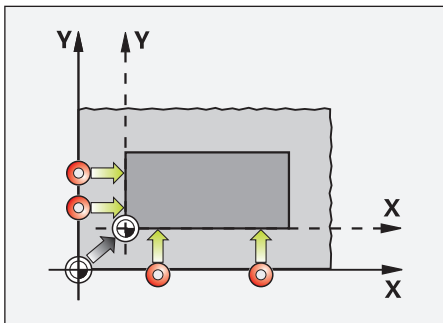

Preset management with the preset table

Preset management enables flexible machining, shorter setup times, and higher throughput. Setting up your machine is greatly simplified.

In preset management, you can save **any number of presets** and assign an individual basic rotation to each one. In order to permanently save fixed presets in the machine's workspace, you can also write-protect individual lines.

There are three possibilities for rapidly saving the presets:

- Via a soft key in Manual mode
- Via the probing functions
- With the automatic probing cycles

Saving datums

Datum tables let you save positions or measured values from the workpiece. Datums are always defined relative to the active preset.

NO	DOC	X	Y	Z	SPC	SPB	SPA
0		+0	+0	+0	+0	+0	+0
1		+0	+0	+300	+0	+0	+0
2		+0	+0	+0	+0	+0	+0
3		+0	+0	+0	+0	+0	+0
4		+0	+0	+0	+0	+0	+0
5		+0	+0	+0	+0	+0	+0
6		+0	+0	+0	+0	+0	+0
7		+0	+0	+0	+0	+0	+0
8		+0	+0	+0	+0	+0	+0
9		+0	+0	+0	+0	+0	+0

DOC	Text width 16		TNC:\table\preset.pr
	100% S-OVR		
	100% F-OVR	S1	LIMIT 1
X	-17.896	A	+0.000
Y	+72.756	C	+0.003
Z	-5.000		

Mode: NOML... T 12 Z S 1800 F 3000mm/min Ovr 100% M 5/9

Buttons: CHANGE PRESET, BASE TRANSFORM. OFFSET, ACTIVATE PRESET, END

Programming, editing, testing

A full range of possibilities with the TNC 640

Besides being universally deployable, the TNC 640 is equally flexible when it comes to programming and editing.

Positioning with Manual Data Input

You don't need to create a complete program in order to start machining with the TNC 640. You can machine a workpiece step by step using both manual machining and automatic positioning in any sequence.

Programming at the machine

HEIDENHAIN controls are designed for shop-friendly programming right at the machine. Instead of requiring you to know G-codes, the Klartext conversational programming language provides its own buttons and soft keys for programming straight lines, arcs, and cycles. At the push of a button, HEIDENHAIN Klartext dialog guidance opens and actively helps you during programming on the TNC. Its clear instructions prompt you to enter all of the required data.

All interface texts, including Klartext tips, dialog prompting, program steps, and soft keys, are available in numerous languages.

And even if you prefer **ISO programming**, the TNC is still the right control: you can enter ISO command letters via soft keys or directly on the alphanumeric keyboard.

Creating programs offline

The TNC 640 is also well equipped to handle offline programming. Its interfaces allow the control to be integrated into networks in order to connect with programming stations or other data storage media.

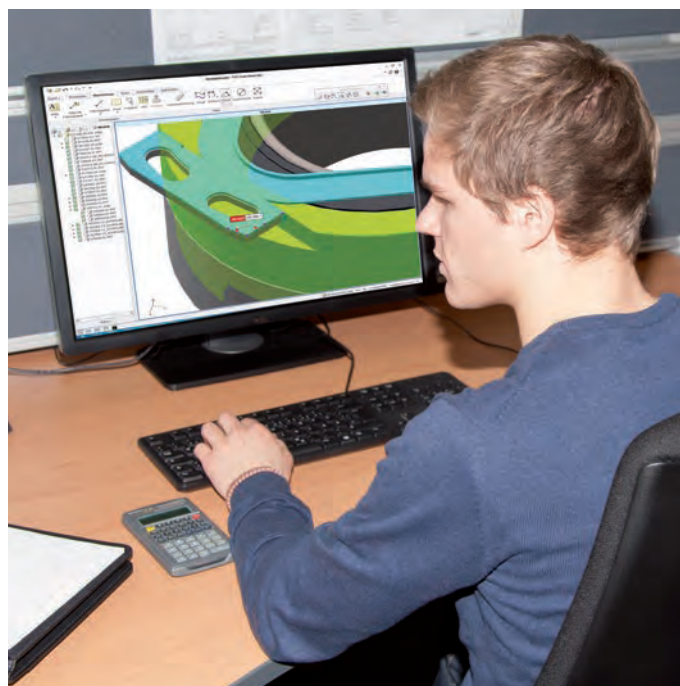

Graphical support in any scenario

Programming graphics

The two-dimensional programming graphics give you additional assurance: while you are programming, the TNC 640 renders every programmed movement on the screen. You can opt for a plan view, side view, or front view. Tool paths or rapid-traverse movements can be hidden, and the image's scale can be changed.

Program verification graphics

For added certainty prior to machining, the TNC 640 can simulate and render the machining of the workpiece at high resolution. This simulation can be viewed in different formats:

- Plan view at different levels of depth
- Three projections
- 3-D view

The type and quality of the image can be selected, and details can be displayed at magnification. The TNC 640 also displays the calculated machining time in hours, minutes, and seconds.

The 3-D view lets you display the programmed tool-center path in three dimensions, and a powerful zoom function lets you see even the tiniest details. The 3-D line graphics are especially helpful in verifying programs created offline, allowing you to avoid undesired machining marks on the workpiece, such as those that occur when the postprocessor outputs points incorrectly. The 3-D view of the TNC also provides a measuring function. When you move the mouse pointer anywhere within the image, the coordinates of that position are displayed. The measurement window also displays tool information.

During the machining simulation, the TNC 640 can also display all of the machine components defined by the machine manufacturer, in addition to the workpiece and tool. This rendering capability is particularly useful in Test Run mode, informing you ahead of time which positions are too close to components and when the traversing path will be insufficient. This is a huge benefit during machining with tilting axes.

Program-run graphics

The program-run graphics display the workpiece in real time in order to show you the machining progress. Direct observation of the workpiece is usually impossible due to coolant and the safety enclosure. During machining, you can switch between various operating modes at any time in order to create programs, for example. And at the press of a button, you can cast a glance at the machining progress while programming.

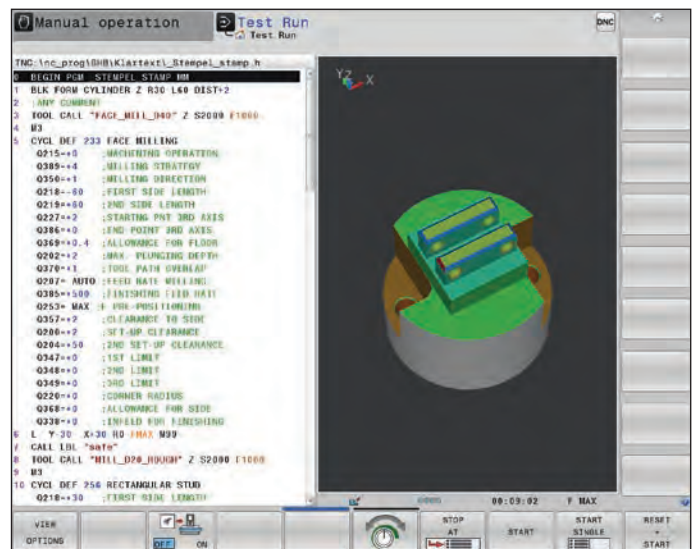
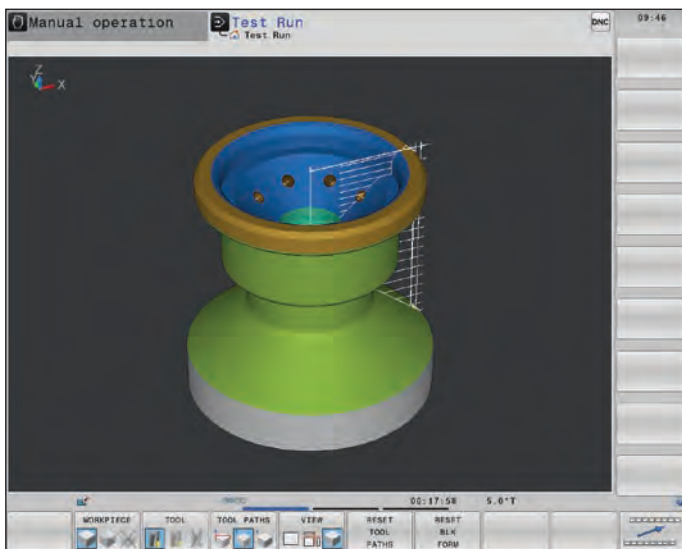

Programming in the shop

Straightforward function keys for complex contours

Programming 2-D contours

Two-dimensional contours are the bread and butter of a modern machine shop, which is why the TNC 640 offers a variety of ways to handle them. And regardless of whether you are programming a milling or turning contour, you can always use the same tools. This allows you to program as always without a shift in thinking.

Programming with function keys

Are the contours properly dimensioned for NC machining? In other words, are the end points of the contour elements provided in either Cartesian or polar coordinates? If yes, then you can create the NC program straightaway using function keys.

Straight lines and circular elements

To program a line segment, for example, simply press the linear traverse key. The Klartext conversational programming language of the TNC 640 then prompts you for all of the information needed by the programming block, including the target coordinates, feed rate, tool compensation value, and machine functions. Function keys for circular movements, chamfers, and corner rounding also simplify your programming work. In order to avoid surface blemishes during approach or departure from the contour, movement must be seamless—that is, tangential.

You simply specify the starting point or end point of the contour and the approach or departure radius of the tool. The control handles the rest.

The TNC 640 can foresee a contour with radius compensation by up to 99 blocks, thus taking back-cutting into account and avoiding contour gouging. This could be the case, for example, when roughing a contour with a large tool.

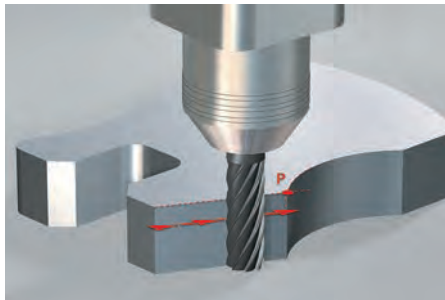

 Straight line defined by its end point

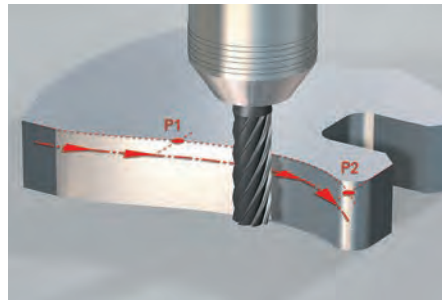

 Circular path with seamless (tangential) transition from the preceding contour element, defined by its end point

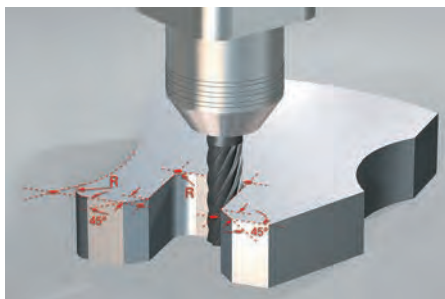

 Corner rounding: circular path with a seamless (tangential) transition, defined by its radius and corner point

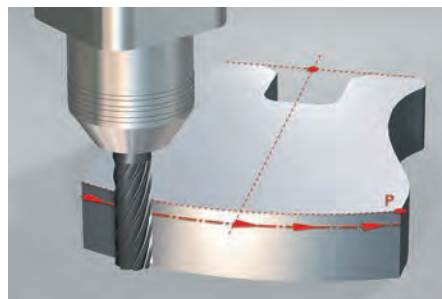

 Circular path defined by its center, end point, and rotational direction



 Chamfer defined by the corner point and chamfer length

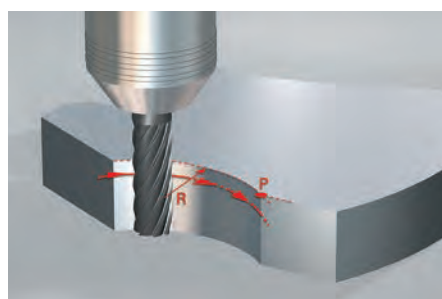

 Circular path defined by its radius, end point, and rotational direction

Programming free contours and Data Matrix codes

FK free contour programming

Not all workpieces are properly dimensioned in accordance with the ISO standard. Thanks to FK, the control's programming function for free contours, you can simply enter the known data without needing to convert or calculate anything! In such cases, individual contour elements can remain undefined as long as the overall contour itself is defined. If the data from the drawing yields more than one possible mathematical solution, then the helpful TNC 640 programming graphics show you the possible variants for your selection.

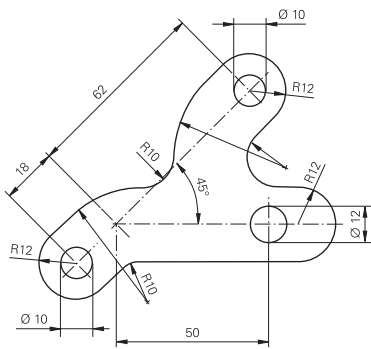

Program machining patterns with ease and flexibility

Positions to be machined are often arranged in patterns on the workpiece. The TNC 640's graphical support helps you program a wide range of machining patterns with ease and exceptional flexibility. You can define as many point patterns as desired with various numbers of points. During machining, you can then have all of the points executed as a unit, or each point individually.



Fast and easy programming of a scannable Data Matrix code

Cycle 224 (Data Matrix code pattern) lets you convert any text into a Data Matrix code and machine it onto your workpiece as a point pattern using, say, drilling operations. The Data Matrix code can be decoded with common scanning devices. Serial numbers and production data can thus be permanently machined onto the part. All you need to do after defining a machining cycle is enter the text (up to 255 characters) into the cycle and specify the size and position of the drilling pattern. The control automatically calculates the Data Matrix code and performs the machining work on its own.

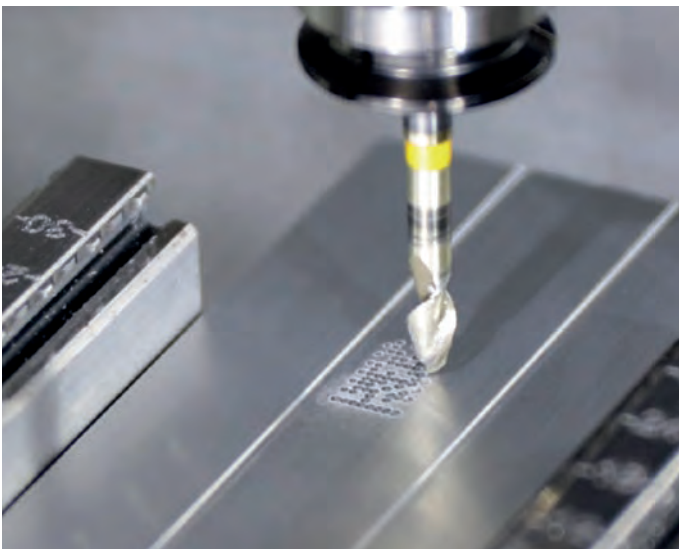

Programming in the shop

Practical cycles for recurring operations

Extensive machining cycles for milling and drilling

Frequently recurring operations consisting of multiple machining steps are stored as cycles in the TNC 640. Dialog guidance and help graphics illustrating the required input parameters support you in programming them.

Standard cycles

In addition to drilling and tapping cycles (with or without a floating tap holder), a variety of selectable cycles are available:

- Thread milling
- Reaming
- Engraving
- Boring
- Hole patterns
- Milling cycles for face milling a flat surface
- Roughing and finishing of pockets, slots, and studs

Cycles for complex contours

Of great help in roughing pockets with any contour are the control's **SL cycles** (SL = Subcontour List) and **OCM** (Optimized Contour Milling) functionality. These functions refer to roughing and finishing cycles in which the contour or subcontours are defined in subprograms. Thus, a single contour description can be used for more than one operation with different tools.

Up to twelve **subcontours** can be superimposed for the machining operation. The control automatically calculates the resulting contour and the tool paths for roughing or clearing the surfaces. Subcontours can be pockets or islands. Multiple pockets are combined to form a single pocket, with the tool bypassing any islands.

During roughing, a **finishing allowance** on the wall and floor surfaces is also taken into

account by the TNC 640. When **roughing** with different tools, the control identifies residual material to be removed by smaller tools. A separate cycle is used for finishing to the final dimensions.

OEM cycles

Machine manufacturers can incorporate their specialized production expertise in the form of additional machining cycles and store them in the TNC 640. The end user can write his own cycles as well. HEIDENHAIN makes this possible with its PC software CycleDesign, which allows you to create input parameters and arrange the TNC 640's soft key structure as desired.

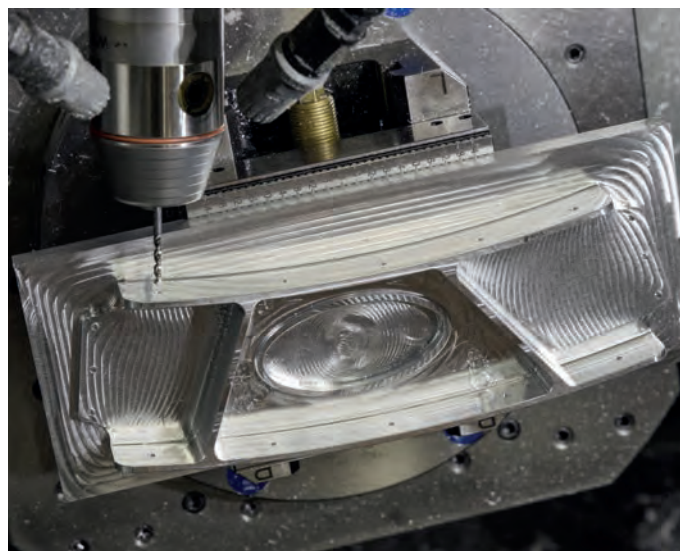

3-D machining with parametric programming

Simple, mathematically easy-to-describe 3-D geometries can be programmed by means of parametric programming. At your disposal are basic arithmetical operations, trigonometric functions, roots, powers, logarithmic functions, parentheses, and logical comparisons with conditional jump instructions. Parametric programming also gives you a simple way to implement 3-D operations. Of course, parametric programming is also well-suited for **2-D contours** that cannot be described with lines or circular arcs but rather through mathematical functions.

Producing gears more effectively*

Highly complex motion sequences are necessary during the machining of gears. The TNC 640 gives you multiple cycles that allow you to produce gears easily and economically. You can choose between these two machining technologies:

- Skiving
- Hobbing

During **skiving**, cutting action is performed by means of an axial tool feed and a rolling motion. Skiving is suitable for the machining of straight or oblique internal and external gear teeth. Significant advantages can be gained through skiving, particularly when machining internal gear teeth. The continuous cutting process involved also enables exceptional surface quality with short process times.

Hobbing is a continuous cutting method suitable for the production of straight or oblique external gear teeth. This method lets you manufacture gears productively, accurately, and flexibly.

In both methods, axial motion is superimposed onto a synchronized rotation of the tool and workpiece. The tool and the workpiece axis must both be positioned at defined angles relative to each other. The TNC 640 handles these complex calculations for you and automatically executes all of the required motion and synchronization.

* Option 157 (with turning mode, option 50 as well)



Programming in the shop

Practical turning cycles (option)

The TNC 640 also offers an extensive and technologically sophisticated package of turning cycles. These cycles are equivalent to the well-proven and long-standing core functions of the HEIDENHAIN lathe controls. The appearance and functions of the user interface, however, are aligned with the familiar and well-proven Klartext conversational programming language. Cycle parameters used for both milling and turning are naturally designated by the same number. Graphical illustrations assist you with program entry in the usual manner for turning as well.

Machining simple contours

Various cycles are available for the longitudinal and transverse machining of simple contours. The area to be machined can also be inclined, thus requiring a plunging movement. Of course, the TNC 640 automatically takes the angle of the turning tool into account.

Machining any contours

If the contours to be machined are complex and can no longer be defined with simple cycle parameters, you can still describe them using contour subprograms. This process is identical to the procedure used for SL cycles in milling, for which you use Cycle 14 to define the subprogram describing the finished contour. You can define the technology parameters in the respective turning cycle.

For the contour description, you use exactly the same Klartext functions as you would for defining a milling contour. FK free contour programming is included as well. Turning-specific recess and undercut contour elements are also available, which you can insert between contour elements in the same manner as chamfers and rounding arcs. Besides radial and axis recesses, E, F, H, K, and U undercuts are available, as are thread undercuts.

Depending on the cycle, the TNC 640 machines parallel to the axis or the contour. You define the machining operations (roughing, finishing) or the oversize with dialog guidance in the corresponding parameters.

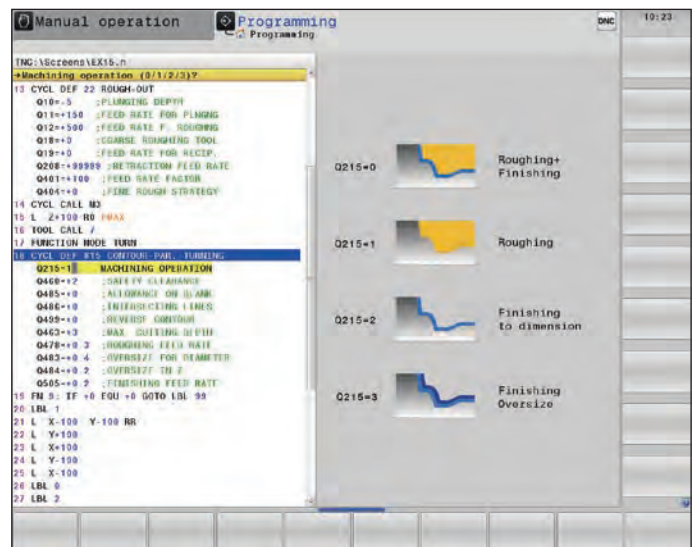

Recessing

For these operations, as well, the TNC 640 features ample flexibility and functionality. Simple longitudinal and transverse recessing operations are possible, as are contour recessing operations in which the cycle is machined along any desired contour. You can work particularly effectively when performing recess turning: due to the direct alternation between infeed and cutting, air cuts are hardly necessary. Here, too, the TNC takes the technological constraints into account (width of recessing tool, overlap, feed-rate factor, etc.) and executes the operations both quickly and reliably.

Simultaneous finishing

Cycle 883 allows you to machine contours requiring different tool inclination angles within a single operation. This cycle synchronously modifies the inclination angle while machining. In order to attain the best-possible surface quality, unnecessary movements of the tilting axes are avoided. Based on the programmed parameters, the cycle automatically calculates a collision-free path.

Thread machining

Simple and extended cycles are available for the longitudinal and transverse machining of cylindrical or tapered threads. You can use cycle parameters to define the manner in which the thread is produced. This enables you to machine a wide variety of materials.

Blank form update

Another highlight of the TNC 640 is its blank form update feature. If you define the workpiece blank at the beginning of your program, the control computes the new blank form for each following step. The machining cycles always adapt to the current workpiece blank. The blank form update feature helps you avoid air cuts and optimize approach paths.

Orientation of the turning tool

On milling-turning machines, it may be necessary to incline the tool during turning or change the side from which machining should be performed. With the help of a cycle, the TNC can change the inclination angle of the tool for back cutting or can convert an external turning tool into an internal turning tool without the operator needing to adjust the cutter position or the orientation angle in the tool table.

Eccentric turning (option)

With the eccentric turning function, you can perform turning operations even if the workpiece axis is not aligned with the axis of rotation due to the setup configuration. During machining, the TNC 640 compensates for any eccentricity with compensating movements in the linear axis coupled with the rotating spindle.

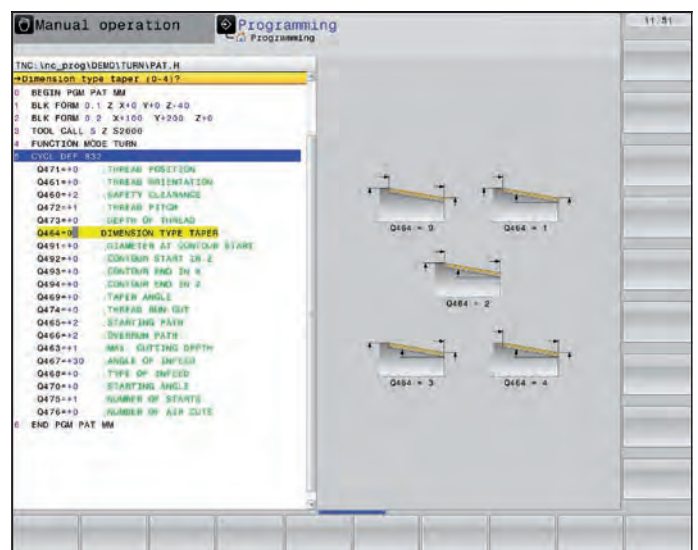
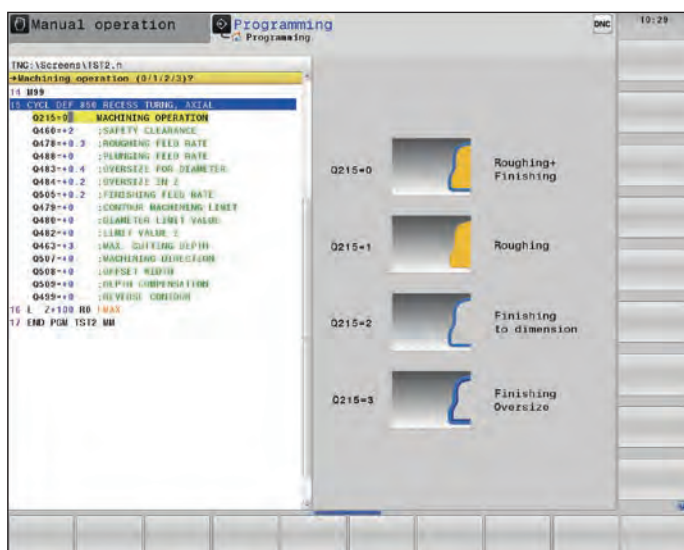

Programming in the shop

Practical functions for grinding and dressing (option)

The TNC 640 also lets you perform grinding operations on your machine. Cycles for jig grinding and dressing allow you to program the respective function with great convenience. In addition, the TNC 640 can superimpose a tool-axis reciprocating stroke onto the programmed movements. Optimized tool management supports the user in every process, including grinding and dressing. The TNC 640 is thus the perfect basis for attaining the highest degree of surface quality and accuracy in your application.

Jig grinding*

Jig grinding is the grinding of a 2-D contour. Jig grinding on a milling machine is primarily used to finish holes or pre-machined contours with a grinding tool. You can program the grinding contour in defined milling cycles and then perform machining. There is also the option of superimposing a tool-axis reciprocating stroke onto the tool's motion. You can define, start, and stop this reciprocating stroke, as well as reset the defined values. The reciprocating stroke enables you to attain uniform grinding tool wear and precise geometries for the surfaces to be ground.

Dressing*

Dressing cycles allow you to true up grinding tools in the machine. During dressing, the grinding tool is machined with a special dressing tool. Klartext cycles are available for dressing the diameter or profile of a grinding tool.

* The machine must be adapted for this function by the machine manufacturer.

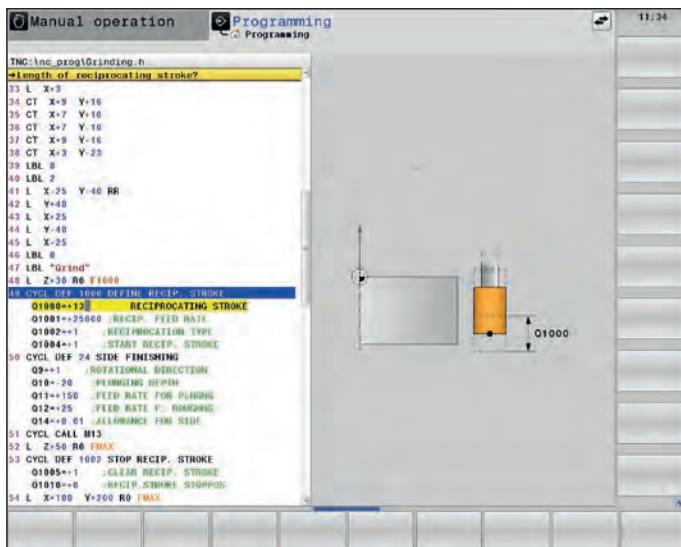

Programming in the shop

Reusing programmed contour elements

Coordinate transformations

If you need a pre-programmed contour at different locations and in different sizes on the workpiece, then the TNC 640 offers you a convenient solution in the form of coordinate transformations. Depending on the operation, you can **shift the datum** (milling, grinding, and turning) and **rotate** the coordinate system (milling and grinding) as well as **mirror** the contour (milling and grinding). With a **scaling factor** (milling and grinding), you can enlarge or reduce contours to account for shrinkage or oversizes.

Program-section repeats and subprograms

Many machining operations repeat themselves either on the same workpiece or on different workpieces. Once you have programmed a detail, there is no need to program it again. With its subprogram technology, the TNC can save you a great deal of programming time.

In **program-section repeats**, you can label a section of the program, and the TNC will repeat this section as many times as required.

You can mark a program section as a **subprogram** and then call it at any point in the program and as often as you want.

With the **program call** function, you can even use a completely separate program at any location in your current program. This allows you to leverage already programmed and frequently required working steps or contours.

Of course, you can also combine these programming techniques as often as desired.

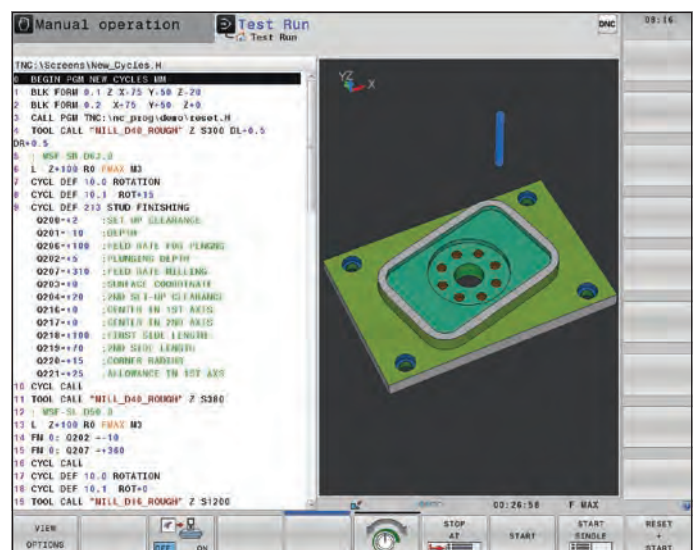

Rapid availability of all information

Do you have questions about a programming step but your User's Manual is not at hand? No problem: both the TNC 640 control and the TNC 640 programming station feature **TNCguide, a convenient help system** that displays the user documentation in a separate window.

You can activate TNCguide simply by pressing the HELP key on the TNC keyboard or by clicking any soft key when the mouse pointer has switched to a question mark. This is easily done by clicking on the help icon permanently displayed on the TNC screen.

TNCguide generally displays the information instantaneously and in the correct context (context-sensitive help), immediately giving you the information you currently need. This function is particularly helpful for soft keys and provides a detailed explanation of their effects.

You can download the documentation in the desired language free of charge from the HEIDENHAIN homepage and save it to the appropriate language directory of the TNC hard disk.

The following user's manuals are available in the help system:

- Klartext Conversational Programming
- Setup, Testing, and Running NC Programs
- Cycle Programming
- DIN/ISO programming
- TNC 640 Programming Station (installed only with the programming station)

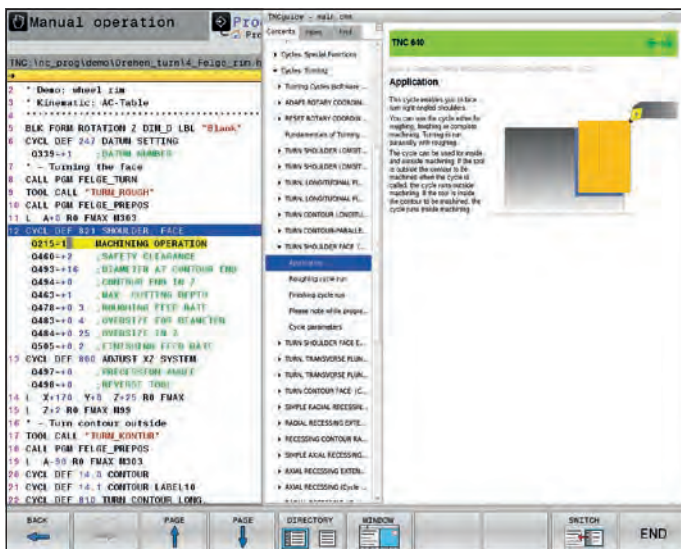

TNCguide integrated into the control, e.g., on the TNC 640 ...

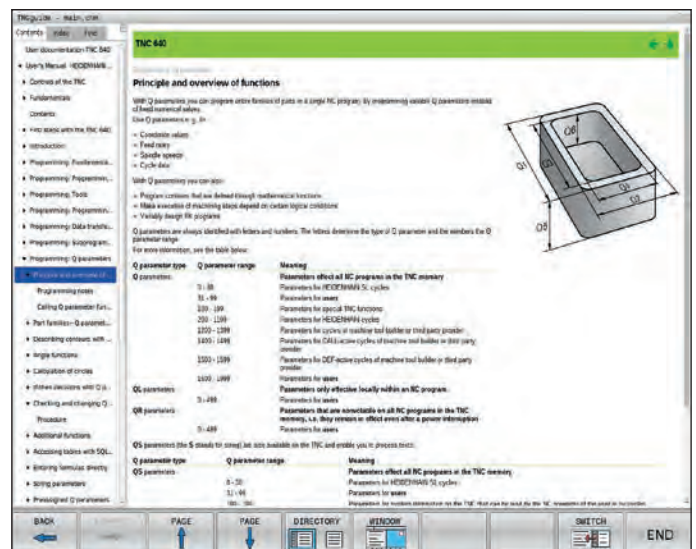

... or on the programming station.

Open to outside information

Processing CAD files with the TNC 640

CAD viewer

With the standardly available CAD viewer software, you can open 3-D CAD models and drawings directly on the TNC 640. Various view options as well as rotation and zoom capabilities allow for a detailed visual inspection and analysis of your CAD data. You can also use the viewer to ascertain position values from a 3-D model. You simply select an arbitrary reference point in your drawing and select the desired contour elements. The CAD viewer then displays the coordinates of the elements in a window. The CAD viewer can depict the following file formats:

- STEP files (.STP and .STEP)
- IGES files (.IGS and .IGES)
- DXF files (.DXF)

CAD Import (option)

Why program complex contours if you already have the drawing as a DXF, STEP, or IGES file? After all, you have the ability to extract contours or machining positions from these types of CAD files. This not only saves time otherwise spent on programming and testing, but you can also be sure that the finished contour is exactly in accordance with the design engineer's specifications.

Extracting machining information directly from CAD data offers additional possibilities, particularly for the creation of NC programs with a tilted machining plane. You can also define the preset with a 3-D basic rotation of the 3-D model and set a datum with the appropriate 3-D rotation in the desired working plane.

You can easily save the working plane to the clipboard and transfer it to the NC program with the appropriate transformation and the associated PLANE command. In the defined working plane, you can extract contours and machining positions, and apply them to the NC program.

Selecting the contour is particularly convenient. You first select any element by clicking it with the mouse. As soon as you have selected a second element, the TNC detects your desired machining direction and initiates automatic contour detection. The TNC automatically selects all clearly identifiable contour elements until the contour closes or branches out. In this manner, you can define extensive contours with just a few mouse clicks. Then you can simply copy the selected contour to an existing Klartext program using the clipboard.



You can also select **machining positions** and save them as point files, especially in order to apply hole positions or starting points for pocket machining. This can be done very easily by selecting the desired area with the mouse. In a pop-up window with a filter function, the TNC displays all of the hole diameters within the area you have selected. To select the desired hole diameters and restrict the number of hole positions, simply click the corresponding filter symbol to change the filter limits. A zoom function and various configuration possibilities round out the functionality of CAD Import.

It is also possible to define the contour program's resolution for using it in older TNC controls. You can also define a transition tolerance if the contour elements are not completely connected.

The following positions can be defined as presets:

- The beginning, end, or mid-point of a line
- The beginning, end, or center point of a circular arc
- Quadrant transitions or center point of a circle
- Intersection of two lines, regardless of their extension
- Intersection of a line and a circular arc
- Intersection of a line and a circle

If multiple intersections between two elements are possible (e.g., between a straight line and a circle), then you can select the correct intersection with a mouse click.

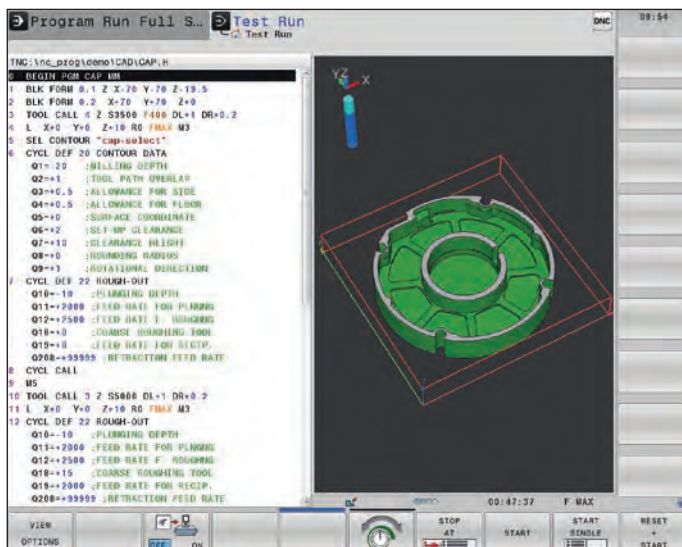

Part program on the basis of an imported DXF file

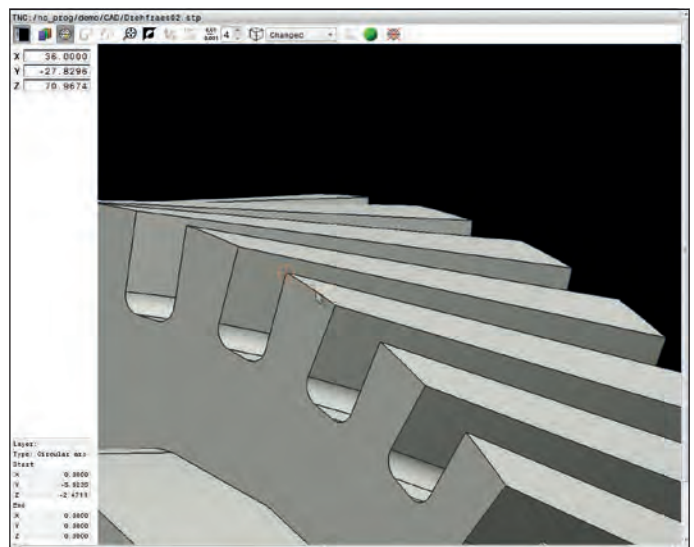

Display of a 3-D model in the CAD viewer

Open to outside information

Uniformly digital job management with Connected Machining

connected + machining

Having a smooth exchange of knowledge is crucial for the success of a company. In order for knowledge to be transferred rapidly and without loss, e-mail communication capability is just as important as the continuous availability of electronic production documents or the transfer of data to ERP and production-activity control systems. Tool and raw material inventories, tool data, workholding drawings, CAD data, NC programs and inspection instructions must all be available to machine operators during all shifts. Economical manufacturing thus requires an efficient process chain and a networked control.

With its Connected Machining package of functions, the TNC 640 control integrates itself flexibly into your process chain and helps you optimize the transfer of knowledge within your company. So let your shop benefit from all of the information available

in your company. Connected Machining enables fully digital job management in a networked production environment:

- Convenient data utilization
- Time-saving workflows
- Transparent processes

Even the basic version of the TNC 640 is equipped with a latest-generation Gigabit Ethernet data interface. The TNC 640 uses the TCP/IP protocol to communicate with NFS servers and Windows networks without requiring additional software. The fast data transfer at rates of up to 1000 Mbit/s ensures very short transmission times. The TNC 640 thus offers the optimal technological foundation for Connected Machining, the networking of the control in the shop with all production-related areas in your company.

The networked TNC 640

With the functions of Connected Machining, integrate the TNC 640 into your corporate network, and connect the shop floor via the control to PCs, programming stations, and other data storage media in the following areas:

- Design
- Programming
- Simulation
- Production planning
- Production

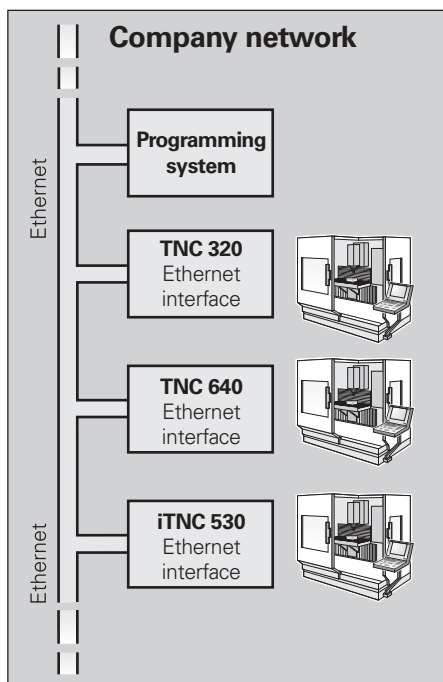

Standard range of functions

In order to be able to use the data that you have transmitted to the control via the standard network connections, the TNC 640 offers you several interesting applications, even in its standard range of functions. The CAD viewer, PDF viewer or Mozilla Firefox web browser enable the simplest form of Connected Machining: access to manufacturing process data right at the control. In this case, operating web-based documentation systems or ERP systems is just as feasible as accessing your e-mail inbox. The following file formats can also be opened directly on the TNC:

- Text files ending in .txt or .ini
- Graphic files ending in .gif, .bmp, .jpg, or .png
- Table files ending in .xls or .csv
- HTML files

Data transfer with TNCremo

An enhanced solution for fully digital job management within the context of Connecting Machining is the free-of-charge **TNCremo** PC software. With it, you can do the following (including over the Ethernet interface):

- Transfer remotely stored part programs and tool or pallet tables in both directions
- Start the machine

With the powerful **TNCremoPlus** PC software, you can also transfer the screen contents from the control to your PC using the live-screen function.

Obtaining operating states

Option 137, State Reporting Interface (SRI), gives you a simple and reliable interface for recording the operating data of your machine. It records the idle times, run times, and fault messages of your machine. SRI also provides historical operating data that can still be retrieved even after the corporate network has been down for hours at a time.

Job-related data

With REMOTE DESKTOP MANAGER (option 133), you can operate a Windows PC right from the TNC 640. From the control, you gain direct access to EDP systems within the process chain and benefit from significantly more efficient setup processes thanks to the reduction in inconvenient legwork between the machine and the office. Technical drawings, CAD data, NC programs, tool data, work instructions, parts lists, and warehouse information are digitally available at the machine. E-mails can be sent and received with ease. Pressing a key on the machine's operating panel conveniently switches you from the screen of the control to the Windows PC interface. The Windows PC can be a computer in the local network or an industrial PC (IPC) in the machine's electrical cabinet.

HEIDENHAIN OPC UA NC Server

Standardization and application relevance are key factors for the economical integration of a control into your production environment. With the OPC UA NC Server, HEIDENHAIN offers a reliable interface for the seamless integration of modern industrial applications.

- *State-of-the-art IT security:* Authentication, authorization, and cryptography
- *Uncomplicated:* Guided connection configuration
- *Application-oriented:* Tailored to the demands of modern industrial applications
- *Standardized:* Industry 4.0-recommended communication technology
- *Freedom of choice:* Open selection of operating system and toolkit
- *Virtual testing environment:* Publicly available HEIDENHAIN programming station

Component monitoring

During their lifecycle, loaded machine components such as guideways and ball screws exhibit wear, thus causing the quality of axis motion to diminish. This, in turn, affects production quality. With Component Monitoring (option 155) and a cycle, the control is able to measure the current machine condition. As a result, any deviations from the machine's shipping condition due to wear and aging can be measured. The machine manufacturer can read and evaluate the data, and react with predictive maintenance, thereby avoiding unplanned machine downtimes.

Detailed data for the optimal organization of production processes

HEIDENHAIN DNC enables, among other things, the connection of TNC controls to inventory management systems and production-activity control systems. Automatic feedback messages about active production processes, for example, can be set up over this interface.

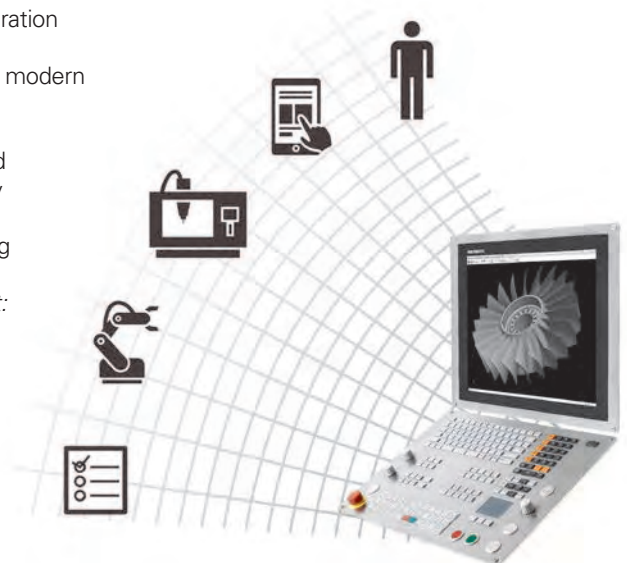

Open to outside information

StateMonitor: collect and evaluate machine data

StateMonitor collects and visualizes the statuses of production machines. By evaluating important data such as the current machine status, machine messages, override positions, and utilization history, StateMonitor provides in-depth information about the machine's degree of utilization. Based on the collected data, StateMonitor also reveals optimization possibilities. The user can enter comments about machine downtimes and setup times in order to uncover machine-specific and organizational optimization potential. Via the messenger function, StateMonitor notifies the right person by e-mail based on individually combinable machine signals and statuses.

StateMonitor collects and visualizes the following information from the networked machines:

- Operating modes
- Override positions (spindle, rapid traverse, feed rate)
- Program status and program name as well as subprograms, if applicable
- Program run time
- SIK number and software number
- Machine messages

Active support for production planning with comprehensive functions for job data collection:

- Creating and assigning jobs
- Starting and terminating jobs
- Entering setup times and interruptions
- Storing additional job data, such as quantities produced

You can even use StateMonitor to connect machines with various types of controls. The StateMonitor software supports the following protocol types: HEIDENHAIN DNC, OPC UA, MTConnect, and Modbus TCP.

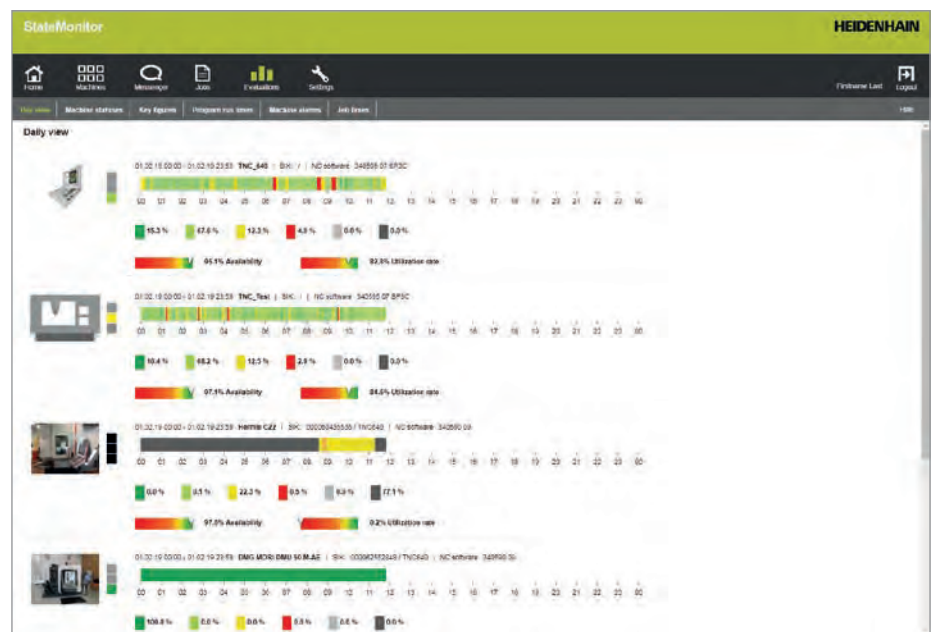
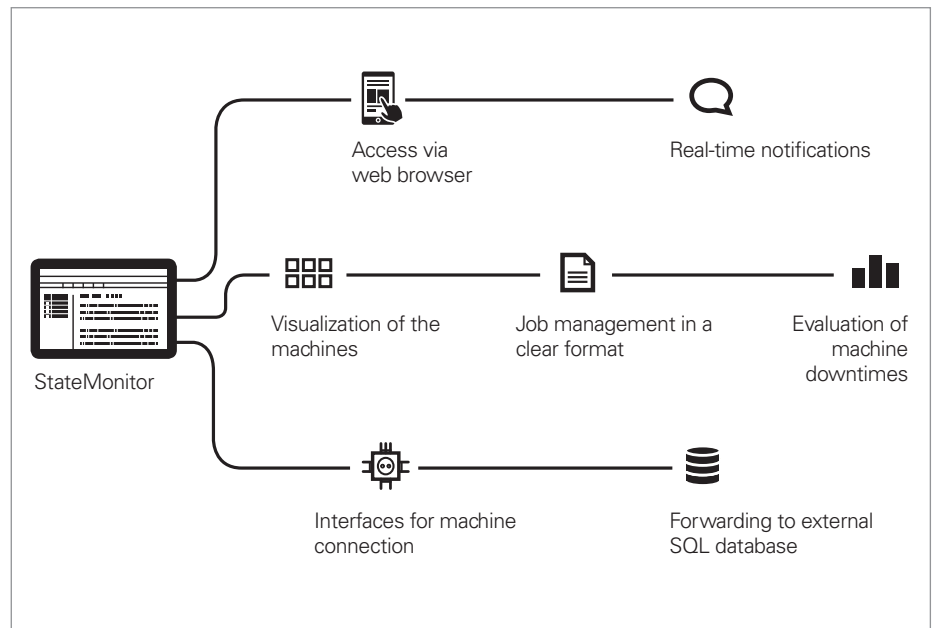

For more information, please contact HEIDENHAIN.

The TNC 640 programming station

Why a programming station?

It is certainly easy to create a part program at the machine using the TNC 640, even while a different part is being machined. Nevertheless, short reloading times or the level of machine utilization may hinder focused programming work on the shop floor. The TNC 640 programming station lets you program exactly as you would at the machine, but away from all the noise and distractions of the shop.

Creating programs

The programming, testing, and optimizing of HEIDENHAIN Klartext or ISO programs with the programming station substantially reduces machine idle times. This is easy to get used to, since every keystroke feels the same. With the programming station, you program using the same keyboard layout that you use at the machine.

Testing programs created offline

Naturally, you can also test programs that were written on a CAD/CAM system. The various views of the program verification graphics help you easily spot contour damage and hidden details.

Training with the programming station

Because the TNC 640 programming station is based on the same software as the TNC 640 control, it is ideally suited for apprentice- and advanced-level training. Programming is performed on the original keyboard unit, and even the test run feature runs exactly as it would on the machine. This gives the trainee the experience needed to safely work on the real machine.

By being programmable in either Klartext or ISO, the TNC 640 programming station is also well suited for TNC programming training in school settings.

Your workstation

The programming station software runs on a PC. The PC screen shows you the same TNC user interface as the control and offers the familiar graphical support. Depending on the version of the programming station, there are multiple ways of using it.

The free **demo version** contains all of the TNC 640's function and allows short programs to be saved. Programming is performed on the PC keyboard.

The version with a **TNC operating panel** lets you create programs in the accustomed manner on a keyboard featuring the same function keys as the control on the machine. It also has a PC keyboard for ISO programming, file names, and comments.

You can also work without the TNC operating panel: a **virtual keyboard** for operating the programming station is shown on the PC screen. This virtual keyboard provides the TNC 640's most important dialog-opening keys.



Workpiece measurement

Setup, preset setting, and measuring with touch trigger probes

Workpiece touch probes* from HEIDENHAIN help you keep costs down in the shop and in serial production: when used in conjunction with the TNC 640, they enable the automated execution of setup, measurement, and inspection functions.

Upon contact with the workpiece surface, the stylus of a TS touch trigger probe is deflected. In that instant, the TS generates a triggering signal that, depending on the model, is transmitted either by cable or an infrared beam to the control.

The touch probes are inserted directly into the machine tool spindle and can be equipped with various taper shanks depending on the machine. The ball tips, which are made of ruby, are available in different diameters and stylus lengths.

* The machine and TNC must be specially adapted by the machine manufacturer.



TS 460

Cable-bound touch probes

For machines requiring manual tool changes, as well as for grinding machines and lathes:

TS 260

- New generation
- Axial or radial cable connection

Wireless touch probes

For machines with an automatic tool changer:

TS 460

- Standard, latest-generation touch probe for radio and infrared transmission
- Compact dimensions
- Energy-saving mode
- Optional collision protection
- Thermal decoupling

TS 642

- Activation via a switch in the taper shank
- Infrared transmission

TS 740

- High scanning accuracy
- High reproducibility
- Low probing forces
- Infrared transmission

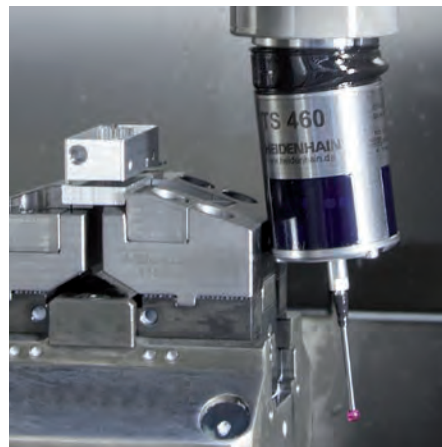

TS 460 with collision protection

Transceiver unit

Radio or infrared transmission is established between the TS or TT touch probe and the SE transceiver:

SE 660

- For radio or infrared transmission (hybrid technology)
- Same SE for TS 460 and TT 460

SE 661

- For radio or infrared transmission (hybrid technology)
- Same SE for TS 460 and TT 460
- EnDat functionality for transmission of the switching state, diagnostics, and additional information



SE 660

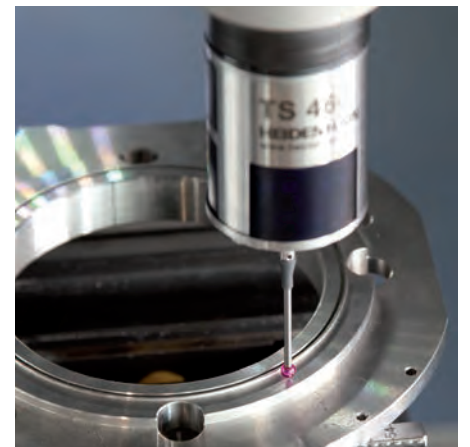

Further information:

Detailed descriptions about workpiece touch probes are available on the Internet at www.tastsysteme.de or in the *Touch Probes* brochure.

Tool measurement

Measuring length, radius, and wear inside the machine

A key factor in obtaining consistently high production quality is, of course, the tool itself. This requires exact measurement of the tool dimensions and periodic inspection of the tool for breakage, wear, and tooth shape. For tool measurement, HEIDENHAIN offers the TT triggering tool touch probes.

These touch probes are installed directly within the machine's workspace, where they permit tool measurement either before machining or during interruptions.

The **TT tool touch probes** measure the tool length and radius. During probing of the rotating or stationary tool, such as for individual tooth measurement, the contact plate is deflected and a trigger signal is transmitted directly to the TNC 640.

The **TT 160** uses cable-bound signal transmission, whereas the **TT 460** sends its signals via radio or infrared transmission. It is thus particularly well suited for use on rotary/tilting tables.

To prevent limiting the machining space and avoid collisions, the TT touch probe must occasionally be removed from the machine. The touch probe's new magnetic base features three contact points and a setting screw. As a result, the touch probe requires calibration only during initial installation and can then be re-installed and removed with a quick hand movement.

- Here are the benefits in a nutshell:
- Fast re-installation without recalibration
 - Low-profile base
 - Same accuracy as a permanent installation

TT 460



Further information:

Detailed descriptions about tool touch probes are available on the Internet at www.tastsysteme.de or in the *Touch Probes* brochure.

Inspecting and optimizing machine accuracy

Easy calibration of rotary axes with KinematicsOpt (option)

Accuracy demands are on the rise, particularly in the realm of 5-axis machining. Complex parts must be manufactured with both precision and reproducible accuracy, including over extended periods of time.

The TNC function **KinematicsOpt** is an important ingredient in helping you meet these high requirements: with a HEIDENHAIN touch probe inserted, a cycle measures your machine's rotary axes fully automatically. Measurement is the same regardless of whether the axis is a rotary table, a tilting table, or a swivel head.

To measure the rotary axes, a calibration sphere is affixed at any position on the machine table and probed with a HEIDENHAIN touch probe. Prior to this, you define the resolution of the measurement and the range that you want to measure for each rotary axis.

Based on the measured values, the TNC calculates the static tilting accuracy. The software minimizes the spatial error arising from the tilting movements and, at the end of the measuring process, automatically saves the machine geometry in the respective machine constants of the kinematics description.

Of course, a detailed log file is also available in which the measured and optimized dispersion (measure of the static tilting accuracy) is saved along with the actual measured values and the actual compensation values.

In order to make optimal use of KinematicsOpt, an especially rigid calibration sphere is required. This reduces deformations arising from the probing forces. For this reason, HEIDENHAIN offers calibration spheres with highly rigid holders available in various lengths.

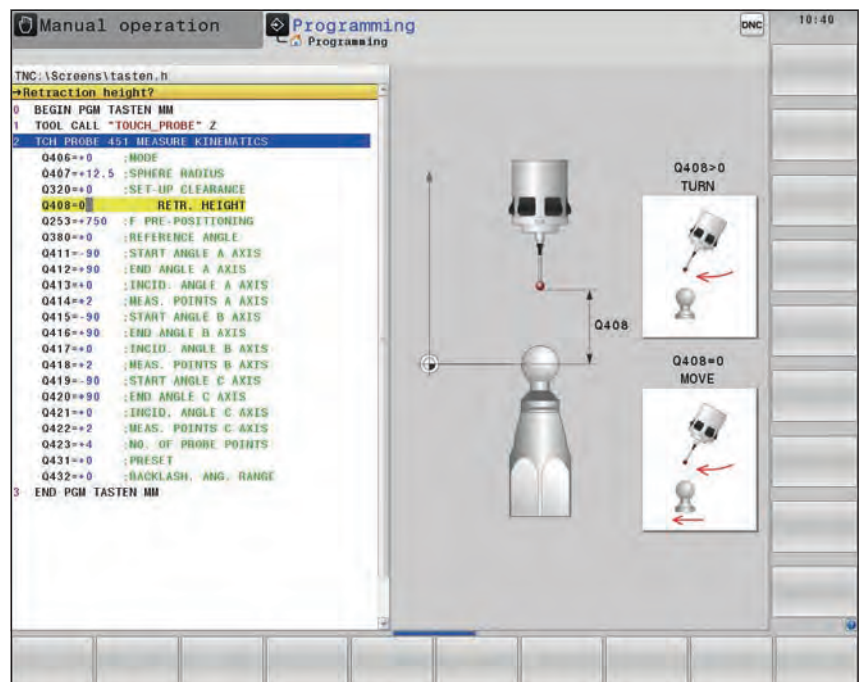

Positioning with an electronic handwheel

Fine motion control of axes

You can set up the workpiece by manually jogging the axes with the axis direction keys, but this task is easier and more finely controllable with the electronic handwheels from HEIDENHAIN.

In this method, the axis slides are moved by the feed motor in accordance with the handwheel's rotation. For particularly high sensitivity, you can incrementally set the amount of traversing distance for each handwheel rotation.

HR 130 panel-mounted handwheels

The HR 130 panel-mounted handwheel from HEIDENHAIN can be integrated into the machine operating panel or mounted to a different part of the machine.

HR 510, HR 520, and HR 550 portable handwheels

The HR 510, HR 520, and HR 550 portable handwheels are particularly helpful when you work in close proximity to the machine's workspace. The axis keys and certain function keys are integrated into the housing. In this way, you can switch axes and set up the machine at any time—regardless of where you happen to be standing. As a wireless handwheel, the HR 550 is ideal for use on large machines. If you no longer need the handwheel, simply attach it to the machine using its built-in magnets.

Expanded range of functions of the HR 520 and HR 550

- Definable traversing distance per revolution
- Display for operating mode, actual position value, programmed feed rate, spindle speed, and error message
- Override potentiometers for feed rate and spindle speed
- Handwheel offset
- Selection of axes by means of keys and soft keys
- Keys for continuous traverse of the axes
- Emergency stop button
- Actual position capture
- NC start/stop
- Spindle on/off
- Soft keys for machine functions to be defined by the machine manufacturer



HR 550



Overview

User functions

User functions	Standard	Option	
Short description	✓	0-7 77 78	Basic version: 3 axes plus closed-loop spindle A total of 14 additional NC axes or 13 additional NC axes plus second spindle
	✓		Digital current and speed control
Program entry	✓ ✓	42	HEIDENHAIN Klartext conversational programming language ISO programming Importing of contours or machining positions from CAD files (STP, IGS, DXF) and saving them as a Klartext contour program or Klartext point table
Position entry	✓ ✓		Nominal positions for straight lines and arcs in Cartesian coordinates or polar coordinates Incremental or absolute dimensions Display and entry in mm or inches
Tool compensation	✓ ✓	9	Tool radius in the working plane and tool length Radius-compensated contour look-ahead for up to 99 blocks (M120) Three-dimensional tool-radius compensation for later modification of tool data without the need for program recalculation
Tool tables	✓		Multiple tool tables with any number of tools
Cutting data	✓		Automatic calculation of spindle speed, cutting speed, feed per tooth, and feed per revolution
Constant contour speed	✓ ✓		Relative to the path of the tool center point Relative to the tool's cutting edge
Parallel operation	✓		Program creation with graphical support while another program is running
3-D machining	✓	9 9 9 9 9 92	Motion control with highly smoothed jerk 3-D tool compensation via surface-normal vectors Alteration of the swivel head angle via the electronic handwheel during program run without changing the position of the tool center point (TCPM = Tool Center Point Management) Keeping the tool perpendicular to the contour Tool radius compensation perpendicular to the tool direction Manual traverse in the active tool-axis system 3-D radius compensation based on the tool's contact angle
Rotary table machining		8 8	Programming of contours for machining on a cylinder as if in two axes Feed rate in mm/min
Turning		50 50 50 50 50 50 50 50 50 50 158	Program-controlled switching capability between milling and turning Constant cutting speed Cutter radius compensation Cycles for roughing, finishing, recessing, thread turning, and recess turning Blank-form updating in contour cycles Turning-specific contour elements for recesses and undercuts Orientation of the turning tool for external turning / internal turning Inclined turning Speed limiting Eccentric turning (additionally required: option 135) Simultaneous turn finishing

User functions	Standard	Option	
Contour elements	✓ ✓ ✓ ✓ ✓ ✓ ✓	50 50	Straight line Chamfer Circular path Circle center Circle radius Tangentially connecting circular arc Corner radii Recess Undercut
Approaching and departing the contour	✓ ✓		Via straight line: tangential or perpendicular Via circular arc
Adaptive Feed Control		45	AFC adapts the contouring feed rate to the current spindle power
Collision monitoring		40 40 40	Dynamic Collision Monitoring (DCM) Graphic depiction of the active collision objects Tool carrier monitoring
FK free contour programming	✓		FK free contour programming in the HEIDENHAIN Klartext conversational programming language with graphical support for workpiece drawings not dimensioned for NC
Program jumps	✓ ✓ ✓		Subprograms Program-section repeat Any program as a subprogram
Fixed cycles	✓ ✓ ✓ ✓ ✓ ✓ ✓ ✓ ✓ ✓ ✓ ✓ ✓	50 50 50 50 50 50+ 131 96 50+ 158 156 157 167	Drilling, tapping (with or without floating tap holder), rectangular and circular pockets Peck drilling, reaming, boring, counterboring, centering Area clearance cycles, longitudinal and transverse, paraxial and contour-parallel Recessing cycles, radial/axial Radial/axial recess turning cycles (combined recessing and roughing motion) Milling of internal and external threads Turning of internal and external threads Hobbing Interpolation turning Simultaneous finishing for turning operations Function for grinding operation Gear-system production Clearing of level and oblique surfaces Complete machining of rectangular and circular pockets, rectangular and circular studs Complete machining of straight and circular slots Point patterns on a circle and lines Point pattern: Data Matrix code Contour train, contour pocket Contour slot with trochoidal milling Engraving cycle: engraving of text or numbers in a straight line or arc Integratability of OEM cycles (special cycles developed by the machine manufacturer) Optimized Contour Milling (OCM) cycles: optimization of roughing processes

Overview

User functions (continued)

User functions	Standard	Option	
Coordinate transformations	✓	8 44	Shifting, rotating, mirroring, scaling (axis-specific) Tilting the working plane, PLANE function Global Program Settings make it possible to manually define shifts, rotations, and handwheel superimpositioning
Q parameters Programming with variables	✓ ✓ ✓ ✓ ✓		Mathematical functions =, +, -, *, /, sin α, cos α, tan α, arc sin, arc cos, arc tan, a ⁿ , e ⁿ , ln, log, \sqrt{a} , $\sqrt{a^2 + b^2}$ Logical operations (=, = /, <, >) Calculating with parentheses Absolute value of a number, constant π, negation, truncation of digits before or after the decimal point Functions for calculation of circles Functions for text processing
Programming aids	✓ ✓ ✓ ✓ ✓ ✓		Calculator Complete list of all current error messages Context-sensitive help function for error messages TNCguide: the integrated help system; user information available directly on the TNC 640 Graphical support for the programming of cycles Comment and structure blocks in the NC program
Teach-in	✓		Application of actual positions directly in the NC program
Program verification graphics Display modes	✓ ✓ ✓		Graphical simulation of the machining operation, even while another program is being executed Plan view / projection in three planes / 3-D view, also in tilted working plane / 3-D line graphics Detail zoom
Programming graphics	✓		Rendering (2-D pencil trace graphics) of entered NC blocks in Programming and Editing mode, even while another program is being executed
Program-run graphics Display modes	✓ ✓		Real-time graphical simulation during execution of the milling program Plan view / view in three planes / 3-D view
Machining time	✓ ✓		Calculation of machining time in the Test Run operating mode Display of the current machining time in the Program Run operating modes
Returning to the contour	✓ ✓		Mid-program startup at any block in the program and movement to the calculated nominal position for continuation of the machining operation Program interruption, contour departure, and return
Preset management	✓		One table for storing any presets
Datum tables	✓		Multiple datum tables for storing workpiece-specific datums
Pallet tables	✓	154	Pallet tables (with any number of entries for the selection of pallets, NC programs, and datums) can be executed for workpiece-oriented machining Production process planning with Batch Process Manager

User functions (continued) and accessories

User functions	Standard	Option	
Touch probe cycles	✓ ✓ ✓ ✓	48	Touch probe calibration Manual or automatic compensation of workpiece misalignment Manual or automatic preset setting Automatic tool and workpiece measurement KinematicsOpt: automatic measurement and optimization of the machine's kinematic model
Parallel secondary axes	✓ ✓ ✓		Compensation of movement in the secondary axes U, V, W through the principal axes X, Y, Z Movements of parallel axes included in the position display of the associated principal axis (sum display) Defining the principal and secondary axes in the NC program enables execution on different machine configurations
Conversational languages	✓		English, German, Czech, French, Italian, Spanish, Portuguese, Swedish, Danish, Finnish, Dutch, Polish, Hungarian, Russian (Cyrillic), Chinese (traditional, simplified), Slovenian, Slovak, Norwegian, Korean, Turkish, Romanian
CAD viewer	✓		Display of standardized CAD file formats on the TNC

Accessories	
Electronic handwheels	<ul style="list-style-type: none"> • HR 510: portable handwheel, or • HR 520: portable handwheel, or • HR 550: portable radio handwheel, or • HR 130: panel-mounted handwheel
Workpiece measurement	<ul style="list-style-type: none"> • TS 260: workpiece touch probe with cable connection, or • TS 248: workpiece touch probe with reduced deflection force, or • TS 460: workpiece touch probe with radio or infrared transmission, or • TS 642: workpiece touch probe with infrared transmission, or • TS 740: workpiece touch probe with infrared transmission
Tool measurement	<ul style="list-style-type: none"> • TT 160: tool touch trigger probe, or • TT 460: tool touch trigger probe with radio or infrared transmission
Programming station	Control software for PCs for programming, archiving, and training <ul style="list-style-type: none"> • Single-station license with original control operating panel • Single-station license with operation via virtual keyboard • Network license with operation via virtual keyboard • Demo version (operated with PC keyboard—free of charge)
Software for PCs	<ul style="list-style-type: none"> • TeleService: software for remote diagnostics, monitoring, and operation • CycleDesign: software for creating your own cycle structure • TNCremo: software for data transfer—free of charge • TNCremoPlus: software for data transfer with live-screen function • State Monitor: software for recording, evaluating, and visualizing machine data

Overview

Options

Option number	Option	With NC software 34059x- or later	ID	Comment
0 1 2 3 4 5 6 7	Additional axis	01	354540-01 353904-01 353905-01 367867-01 367868-01 370291-01 370292-01 370293-01	One to eight additional control loops
8	Advanced Function Set 1	01	617920-01	Rotary table machining <ul style="list-style-type: none"> • Programming of contours for machining on a cylinder as if in two axes • Feed rate in mm/min Interpolation: circular in 3 axes with tilted working plane Coordinate transformation: tilting the working plane, PLANE function
9	Advanced Function Set 2	01	617921-01	Interpolation: straight line in more than four axes (export license required) 3-D machining <ul style="list-style-type: none"> • 3-D tool compensation via surface normal vectors • Alteration of the swivel head angle via the electronic handwheel during program run without changing the position of the tool center point (TCPM = Tool Center Point Management) • Keeping the tool perpendicular to the contour • Tool radius compensation perpendicular to the tool direction • Manual traverse in the active tool-axis system
18	HEIDENHAIN DNC	01	526451-01	Communication with external PC applications over COM component
40	DCM Collision	02	526452-01	Dynamic Collision Monitoring (DCM)
42	CAD Import	08	526450-01	Import of contours from 2-D and 3-D models (e.g., STEP, IGES, DXF)
44	Global PGM Settings	08	576057-01	Global program settings
45	Adaptive Feed Control (AFC)	02	579648-01	Adaptive feed control
46	Python OEM Process	01	579650-01	Python application on the TNC
48	KinematicsOpt	01	630916-01	Touch-probe cycles for the automatic measurement of rotary axes
49	Double-Speed Axes	01	632223-01	Short control-loop cycle times for a direct drive motor
50	Turning	01	634608-01	Turning functions: <ul style="list-style-type: none"> • Tool management for turning • Tool radius compensation • Switching capability between milling mode and turning mode • Turning-specific contour elements • Package of turning cycles • Hobbing
52	KinematicsComp	05	661879-01	Compensation of spatial errors for rotary and linear axes (export license required)

Option number	Option	With NC software 34059x- or later	ID	Comment
56–61	HEIDENHAIN OPC UA NC Server	10	1291434-01 to -06	Reliable and stable interface for the connection of state-of-the-art industry applications; uncomplicated thanks to the use of standardized designs
77	4 Additional Axes	01	634613-01	4 additional control loops
78	8 Additional Axes	01	634614-01	8 additional control loops
92	3D-Tool Comp	07	679678-01	3-D radius compensation based on the contact angle (only with the Advanced Function Set 2 software option)
93	Extended Tool Management	01	676938-01	Extended tool management
96	Advanced Spindle Interpolation	05	751653-01	Cycles for interpolation turning
101–130	OEM options	02	579651-01 to -30	Options of the machine manufacturer
131	Spindle Synchronism	05	806270-01	Synchronization of two or more spindles
133	Remote Desk. Manager	01	894423-01	Display and remote operation of external computer units (e.g., a Windows PC)
135	Synchronizing Functions	04	1085731-01	Advanced synchronization of axes and spindles
136	Visual Setup Control	06	1099457-01	VSC: camera-based monitoring of the setup situation
137	State Reporting Interface	09	1232242-01	Obtaining operating states
141	Cross Talk Comp.	02	800542-01	CTC: compensation of axes coupling
142	Pos. Adapt. Control	02	800544-01	PAC: position-dependent adaptation of the control parameters
143	Load Adapt. Control	02	800545-01	LAC: load-dependent adaptation of the control parameters
144	Motion Adapt. Control	02	800546-01	MAC: motion-dependent adaptation of the control parameters
145	Active Chatter Control	02	800547-01	ACC: active suppression of chatter during heavy machining
146	Active Vibration Damping	04	800548-01	AVD: active suppression of vibration
154	Batch Process Manager	08	121952-01	Depiction of pallet management in a clear format
155	Component Monitoring	09	1226833-01	Function for the monitoring of components for overload and wear

Overview

Options (continued)

Option number	Option	With NC software 34059x- or later	ID	Comment
156	Grinding	10	1237232-01	Grinding functions: <ul style="list-style-type: none"> • Jig grinding • Ability to switch between normal operation and dressing mode • Reciprocating stroke • Grinding cycles • Tool management for grinding and dressing
157	Gear Cutting	09	1237235-01	Machining of gear teeth
158	Advanced Function Set Turning	09	1237237-01	Advanced turning functions
160	Integrated FS: Basic	10	1249928-01	Only with Gen 3: enabling of functional safety (FS) and enabling of four safe control loops
161	Integrated FS: Full	10	1249929-01	Only with Gen 3: enabling of functional safety (FS) and enabling of the maximum number of safe control loops (≥ 10)
162	Add. FS Ctrl. Loop 1	10	1249930-01	Only with Gen 3: additional safe control loop 1
163	Add. FS Ctrl. Loop 2	10	1249931-01	Only with Gen 3: additional safe control loop 2
164	Add. FS Ctrl. Loop 3	10	1249932-01	Only with Gen 3: additional safe control loop 3
165	Add. FS Ctrl. Loop 4	10	1249933-01	Only with Gen 3: additional safe control loop 4
166	Add. FS Ctrl. Loop 5	10	1249934-01	Only with Gen 3: additional safe control loop 5
167	Optimized Contour Milling (OCM)	10	1289547-01	Optimization of roughing processes

Specifications

Specifications	Standard	Option	
Components	✓ ✓ ✓ ✓		MC main computer CC or UxC controller unit BF monitor (19-inch or 24-inch) TE operating panel (suitable for 19-inch or 24-inch monitor)
Operating system	✓		HEROS 5 real-time operating system for machine control
Memory	✓ ✓		4 GB of RAM NC program memory: SDDR, approx. 32 GB HDR, approx. 320 GB
Input resolution and display step	✓ ✓		Linear axes: down to 0.01 µm Rotary axes: down to 0.00001°
Input range	✓		Maximum 999 999 999 mm or 999 999 999°
Interpolation	✓ ✓ ✓	9 8	Linear in 4 axes Linear in up to 6 axes (export license required) Circular in 2 axes Circular in 3 axes with tilted working plane Helical: superimposition of circular and straight paths
Block processing time	✓		0.5 ms (3-D straight line without radius compensation)
Axis feedback control	✓ ✓ ✓ ✓		Position-loop resolution: signal period of the position encoder/1024 Position controller cycle time: 200 µs (100 µs with option 49) Speed controller cycle time: 200 µs (100 µs with option 49) Current controller cycle time: minimum 100 µs (minimum 50 µs with option 49)
Spindle speed	✓		Maximum 100 000 rpm (with 2 pole pairs)
Error compensation	✓ ✓		Linear and nonlinear axis error, backlash, reversal peaks during circular movements, reversal error, thermal expansion Static friction, sliding friction
Data interfaces	✓ ✓ ✓ ✓	18 56–61	One each: RS-232-C/V.24 max. 115 kbit/s Extended data interface with LSV2 protocol for remote operation of the TNC over the data interface with the TNCremo or TNCremoPlus software from HEIDENHAIN 2 x Gigabit Ethernet interface 1000BASE-T 5 x USB (1 x front USB 2.0, 4 x USB 3.0) HEIDENHAIN-DNC for communication between a Windows application and the TNC (DCOM interface) HEIDENHAIN OPC UA NC Server Reliable and stable interface for the connection of state-of-the-art industrial applications
Diagnostics	✓		Fast and simple troubleshooting through integrated diagnostic aids
Ambient temperature	✓ ✓		Operation: +5 °C to +40 °C Storage: -20 °C to +60 °C

Overview

Comparison of controls

Comparison of controls	TNC 620 NC SW 81760x-07	TNC 640 NC SW 34059x-10
Area of application	Standard milling	High-end milling / turning / grinding
<ul style="list-style-type: none"> Simple machining centers (up to 8 control loops, max. 2 of which are spindles) 	✓	✓
<ul style="list-style-type: none"> Machine tools / machining centers (up to 24 control loops, max. 4 of which are spindles) 	–	✓
Program entry		
<ul style="list-style-type: none"> HEIDENHAIN Klartext conversational programming language 	✓	✓
<ul style="list-style-type: none"> ISO programming 	✓	✓
<ul style="list-style-type: none"> CAD Import 	Option	Option
<ul style="list-style-type: none"> CAD viewer 	✓	✓
<ul style="list-style-type: none"> FK free contour programming 	Option	✓
<ul style="list-style-type: none"> Extended milling and drilling cycles 	Option	✓
<ul style="list-style-type: none"> OCM cycles 	Option	Option
<ul style="list-style-type: none"> Turning cycles 	–	Option
<ul style="list-style-type: none"> Functions for grinding 	–	Option
NC program memory	1.8 GB	> 21 GB
5-axis and high-speed machining	Option	Option
Block processing time	1.5 ms	0.5 ms
Input resolution and display step (standard)	0.01 µm	0.01 µm
New design of the screen and keyboard	15-inch screen/ 19-inch touchscreen (portrait)	19-inch / 24-inch touchscreen
Touchscreen	✓	✓
Adaptive Feed Control (AFC)	–	Option

Comparison of controls	TNC 620 NC SW 81760x-07	TNC 640 NC SW 34059x-10
Area of application	Standard milling	High-end milling / turning / grinding
Active Chatter Control (ACC)	Option	Option
Dynamic Collision Monitoring (DCM)	–	Option
KinematicsOpt	Option	Option
KinematicsComp	–	Option
Touch probe cycles	Option	✓
Pallet Management	Option	✓
Parallel axis function	✓	✓

- ✓ Standard
- Not available

HEIDENHAIN

DR. JOHANNES HEIDENHAIN GmbH

Dr.-Johannes-Heidenhain-Straße 5

83301 Traunreut, Germany

☎ +49 8669 31-0

FAXI +49 8669 32-5061

E-mail: info@heidenhain.de

www.heidenhain.de

Vollständige und weitere Adressen siehe www.heidenhain.de
For complete and further addresses see www.heidenhain.de

DE	HEIDENHAIN Vertrieb Deutschland 83301 Traunreut, Deutschland ☎ 08669 31-3132 FAXI 08669 32-3132 E-Mail: hd@heidenhain.de	ES	FARRESA ELECTRONICA S.A. 08028 Barcelona, Spain www.farresa.es	PL	APS 02-384 Warszawa, Poland www.heidenhain.pl
	HEIDENHAIN Technisches Büro Nord 12681 Berlin, Deutschland ☎ 030 54705-240	FI	HEIDENHAIN Scandinavia AB 01740 Vantaa, Finland www.heidenhain.fi	PT	FARRESA ELECTRÓNICA, LDA. 4470 - 177 Maia, Portugal www.farresa.pt
	HEIDENHAIN Technisches Büro Mitte 07751 Jena, Deutschland ☎ 03641 4728-250	FR	HEIDENHAIN FRANCE sarl 92310 Sèvres, France www.heidenhain.fr	RO	HEIDENHAIN Reprezentantă Romania Braşov, 500407, Romania www.heidenhain.ro
	HEIDENHAIN Technisches Büro West 44379 Dortmund, Deutschland ☎ 0231 618083-0	GB	HEIDENHAIN (G.B.) Limited Burgess Hill RH15 9RD, United Kingdom www.heidenhain.co.uk	RS	Serbia → BG
	HEIDENHAIN Technisches Büro Südwest 70771 Leinfelden-Echterdingen, Deutschland ☎ 0711 993395-0	GR	MB Milionis Vassilis 17341 Athens, Greece www.heidenhain.gr	RU	OOO HEIDENHAIN 115172 Moscow, Russia www.heidenhain.ru
	HEIDENHAIN Technisches Büro Südost 83301 Traunreut, Deutschland ☎ 08669 31-1337	HR	Croatia → SL	SE	HEIDENHAIN Scandinavia AB 12739 Skärholmen, Sweden www.heidenhain.se
AR	NAKASE SRL. B1653AOX Villa Ballester, Argentina www.heidenhain.com.ar	HU	HEIDENHAIN Kereskedelmi Képviselet 1239 Budapest, Hungary www.heidenhain.hu	SG	HEIDENHAIN PACIFIC PTE LTD Singapore 408593 www.heidenhain.com.sg
AT	HEIDENHAIN Techn. Büro Österreich 83301 Traunreut, Germany www.heidenhain.de	ID	PT Servitama Era Toolsindo Jakarta 13930, Indonesia E-mail: ptset@group.gts.co.id	SK	KOPRETINA TN s.r.o. 91101 Trenčin, Slovakia www.kopretina.sk
AU	FCR MOTION TECHNOLOGY PTY LTD Laverton North Victoria 3026, Australia E-mail: sales@fcrmotion.com	IL	NEUMO VARGUS MARKETING LTD. Holon, 58859, Israel E-mail: neumo@neumo-vargus.co.il	SL	NAVO d.o.o. 2000 Maribor, Slovenia www.heidenhain.si
BE	HEIDENHAIN NV 1760 Roosdaal, Belgium www.heidenhain.be	IN	HEIDENHAIN Optics & Electronics India Private Limited Chetpet, Chennai 600 031, India www.heidenhain.in	TH	HEIDENHAIN (THAILAND) LTD Bangkok 10250, Thailand www.heidenhain.co.th
BG	ESD Bulgaria Ltd. Sofia 1172, Bulgaria www.esd.bg	IT	HEIDENHAIN ITALIANA S.r.l. 20128 Milano, Italy www.heidenhain.it	TR	T&M Mühendislik San. ve Tic. LTD. ŞTİ. 34775 Y. Dudullu – Umraniye-Istanbul, Turkey www.heidenhain.com.tr
BR	HEIDENHAIN Brasil Ltda. 04763-070 – São Paulo – SP, Brazil www.heidenhain.com.br	JP	HEIDENHAIN K.K. Tokyo 102-0083, Japan www.heidenhain.co.jp	TW	HEIDENHAIN Co., Ltd. Taichung 40768, Taiwan R.O.C. www.heidenhain.com.tw
BY	GERTNER Service GmbH 220026 Minsk, Belarus www.heidenhain.by	KR	HEIDENHAIN Korea Ltd. Anyang-si, Gyeonggi-do, 14087 South Korea www.heidenhain.co.kr	UA	Gertner Service GmbH Büro Kiev 02094 Kiev, Ukraine www.heidenhain.ua
CA	HEIDENHAIN CORPORATION Mississauga, Ontario L5T2N2, Canada www.heidenhain.com	MX	HEIDENHAIN CORPORATION MEXICO 20290 Aguascalientes, AGS., Mexico E-mail: info@heidenhain.com	US	HEIDENHAIN CORPORATION Schaumburg, IL 60173-5337, USA www.heidenhain.com
CH	HEIDENHAIN (SCHWEIZ) AG 8603 Schwerzenbach, Switzerland www.heidenhain.ch	MY	ISOSERVE SDN. BHD. 43200 Balakong, Selangor E-mail: sales@isoserve.com.my	VN	AMS Co. Ltd HCM City, Vietnam E-mail: davidgoh@amsvn.com
CN	DR. JOHANNES HEIDENHAIN (CHINA) Co., Ltd. Beijing 101312, China www.heidenhain.com.cn	NL	HEIDENHAIN NEDERLAND B.V. 6716 BM Ede, Netherlands www.heidenhain.nl	ZA	MAFEMA SALES SERVICES C.C. Kyalami 1684, South Africa www.heidenhain.co.za
CZ	HEIDENHAIN s.r.o. 102 00 Praha 10, Czech Republic www.heidenhain.cz	NO	HEIDENHAIN Scandinavia AB 7300 Orkanger, Norway www.heidenhain.no		
DK	TPTEKNIK A/S 2670 Greve, Denmark www.tp-gruppen.dk	NZ	Llama ENGINEERING Ltd 5012 Wellington, New Zealand E-mail: info@llamaengineering.co.nz		
		PH	MACHINEBANKS' CORPORATION Quezon City, Philippines 1113 E-mail: info@machinebanks.com		